

SYLVANIA

SERVICE MANUAL

Main Section

- Specifications
- Preparation for Servicing
- Adjustment Procedures
- Schematic Diagrams
- CBA's
- Exploded Views
- Parts List

When servicing the deck mechanism, refer to MK14 Deck Mechanism Section.

**Deck Mechanism Part No.:
N2466FT**

20" COLOR TV/DVD/VCR

6720FDF

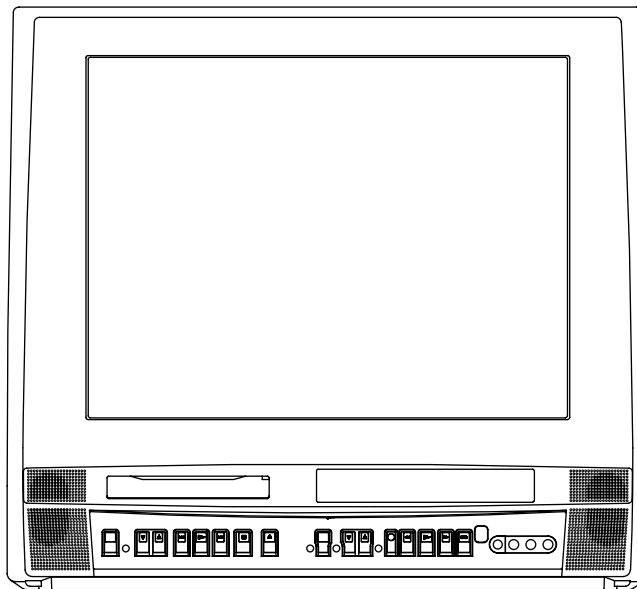

VHS

IMPORTANT SAFETY NOTICE

Proper service and repair is important to the safe, reliable operation of all Funai Equipment. The service procedures recommended by Funai and described in this service manual are effective methods of performing service operations. Some of these service special tools should be used when and as recommended.

It is important to note that this service manual contains various CAUTIONS and NOTICES which should be carefully read in order to minimize the risk of personal injury to service personnel. The possibility exists that improper service methods may damage the equipment. It also is important to understand that these CAUTIONS and NOTICES ARE NOT EXHAUSTIVE. Funai could not possibly know, evaluate and advice the service trade of all conceivable ways in which service might be done or of the possible hazardous consequences of each way. Consequently, Funai has not undertaken any such broad evaluation. Accordingly, a servicer who uses a service procedure or tool which is not recommended by Funai must first use all precautions thoroughly so that neither his safety nor the safe operation of the equipment will be jeopardized by the service method selected.

MAIN SECTION

20" COLOR TV/DVD/VCR

6720FDF

Main Section

- Specifications
- Preparation for Servicing
- Adjustment Procedures
- Schematic Diagrams
- CBA's
- Exploded Views
- Parts List

TABLE OF CONTENTS

Specifications	1-1-1
Laser Beam Safety Precautions	1-2-1
Important Safety Precautions	1-3-1
Standard Notes for Servicing	1-4-1
Preparation for Servicing	1-5-1
Cabinet Disassembly Instructions	1-6-1
Electrical Adjustment Instructions	1-7-1
How to Initialize the TV/DVD/VCR	1-8-1
Firmware Renewal Mode	1-9-1
Block Diagrams	1-10-1
Schematic Diagrams / CBA's and Test Points	1-11-1
Waveforms	1-12-1
Wiring Diagram < VCR Section >	1-13-1
Wiring Diagram < DVD Section >	1-13-2
System Control Timing Charts	1-14-1
IC Pin Function Descriptions	1-15-1
Lead Identifications	1-16-1
Exploded Views	1-17-1
Mechanical Parts List	1-18-1
Electrical Parts List	1-19-1

SPECIFICATIONS

✧ Mode-----SP mode unless otherwise specified

✧ Test input terminal

<Except Tuner>-----Video input (1 Vp-p)

Audio input (-10 dB)

<Tuner>-----Ant. input (80 dBμV) Video: 87.5%

Audio: 25 kHz dev. (1 kHz Sin)

< DEFLECTION >

Description	Condition	Unit	Nominal	Limit
1. Over Scan	---	%	90	5
2. Linearity	Horizontal	%	---	±18
	Vertical	%	---	±10
3. High Voltage	---	kV	27	---

< VIDEO & CHROMA >

Description	Condition	Unit	Nominal	Limit
1. Misconvergence	Center	m/m	---	0.4
	Corner	m/m	---	2.5
	Side	m/m	---	1.5
2. Tint Control Range	---	deg	±30	---
3. Contrast Control Range	---	dB	6	2
4. Brightness (100% White Full Field)	Contrast: Max	ft-L	40	24
5. Color Temperature	---	K	9200	---

< DVD >

Description	Condition	Unit	Nominal	Limit
1. Horizontal Resolution (TDV-540 TIT.2 CHP.16)	---	Line	350	330
2. Video S/N at CN3400 (TDV-540 TIT.2 CHP.6)	---	dB	60	55
3. S/N Chroma at CN3400 (TDV-540 TIT.2 CHP.17)	AM	dB	58	53
	PM	dB	58	53
4. Audio Distortion (LPCM 48 kHz, W/LPF) (PTD 1-NOR TIT.1 CHP.1)	L R	%	0.03	0.07
5. Audio freq. response (LPCM 48 kHz) (PTD 1-NOR TIT.1 CHP.5 -- 10)	L, 20 Hz R, 20 Hz L, 20 kHz R, 20 kHz	dB	0	+4/-5
6. Audio S/N (LPCM 48 kHz, W/LPF, A-WTD) (PTD 1-NOR TIT.1 CHP.1 -- 2)	L R	dB	85	75

< VCR >

Description		Condition	Unit	Nominal	Limit
1. Horizontal Resolution		(R/P, SP)	Line	230	200
2. Jitter (Low)		(R/P, SP)	μs	0.1	0.2
3. S/N Chroma	AM(SP)	(R/P, SP)	dB	38	33
	PM(SP)	(R/P, SP)	dB	38	33
4. Wow & Flutter (JIS, UNWTD)		(R/P, SP)	%	0.25	0.5

< TUNER >

Description		Condition	Unit	Nominal	Limit
1. Video S/N (80 dBμV, TV4ch)		---	dB	45	40
2. Audio S/N (W/LPF)		---	dB	45	40

< NORMAL AUDIO >

All items are measured across 8 Ω resistor at speaker output terminal.

Description		Condition	Unit	Nominal	Limit
1. Audio Output Power		(R/P, SP)	W	1.0	0.8
2. Audio S/N (W/LPF)		(R/P, SP)	dB	40	36
3. Audio distortion (W/LPF, -10 dB 1 kHz IN)		(R/P, SP)	%	3.0	5.0
4. Audio Freq. Response (-10dB 1kHz IN)	200 Hz	(R/P, SP)	dB	-2.0	-2.0±5.0
	8 kHz	(R/P, SP)	dB	0	0±6.0

< Hi-Fi AUDIO >

Description		Condition	Unit	Nominal	Limit
1. Output Level (-10 dB 1 kHz IN)		(R/P, SP)	dB	-8.0	-8±4
2. Audio Distortion (-10 dB 1 kHz IN)		(R/P, SP)	%	0.5	1.0
3. Freq. Response (-15 dB 1 kHz IN)	20 Hz	(R/P, SP)	dB	0	±4
	20 kHz	(R/P, SP)	dB	0	±4

Note: Nominal specifications represent the design specifications. All units should be able to approximate these. Some will exceed and some may drop slightly below these specifications. Limit specifications represent the absolute worst condition that still might be considered acceptable. In no case should a unit fail to meet limit specifications.

LASER BEAM SAFETY PRECAUTIONS

This DVD player uses a pickup that emits a laser beam.

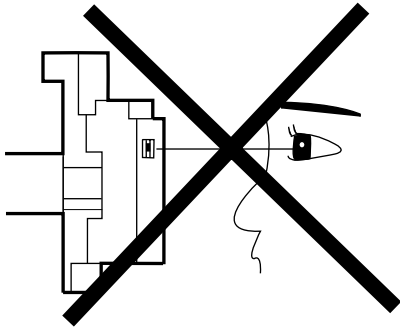

Do not look directly at the laser beam coming from the pickup or allow it to strike against your skin.

The laser beam is emitted from the location shown in the figure. When checking the laser diode, be sure to keep your eyes at least 30 cm away from the pickup lens when the diode is turned on. Do not look directly at the laser beam.

CAUTION: Use of controls and adjustments, or doing procedures other than those specified herein, may result in hazardous radiation exposure.

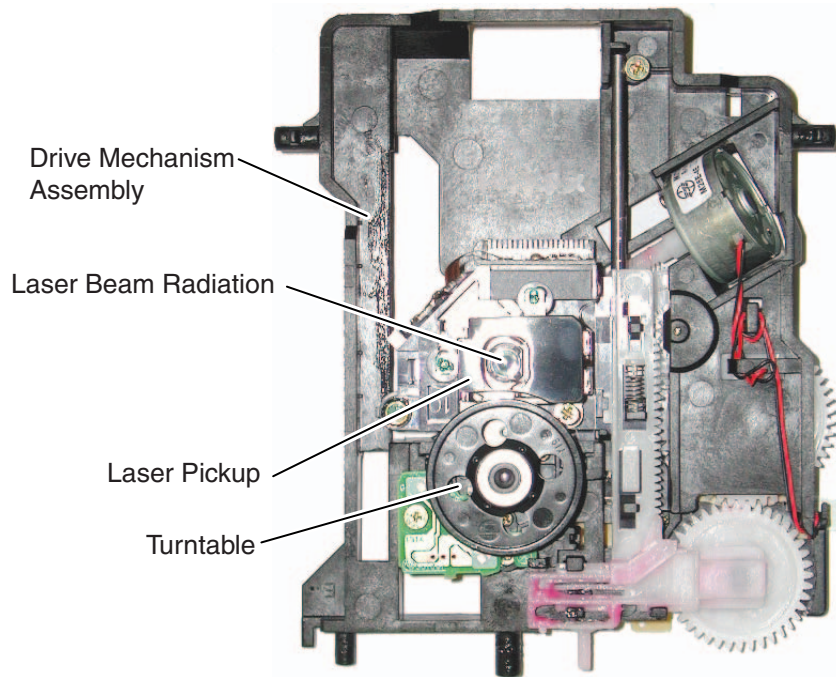

CAUTION
LASER RADIATION
WHEN OPEN. DO NOT
STARE INTO BEAM.

Location: Top of DVD mechanism.

IMPORTANT SAFETY PRECAUTIONS

Prior to shipment from the factory, our products are strictly inspected for recognized product safety and electrical codes of the countries in which they are to be sold. However, in order to maintain such compliance, it is equally important to implement the following precautions when a set is being serviced.

Safety Precautions for TV Circuit

1. **Before returning an instrument to the customer**, always make a safety check of the entire instrument, including, but not limited to, the following items:
 - a. Be sure that no built-in protective devices are defective and have been defeated during servicing. (1) Protective shields are provided on this chassis to protect both the technician and the customer. Correctly replace all missing protective shields, including any removed for servicing convenience. (2) When reinstalling the chassis and/or other assembly in the cabinet, be sure to put back in place all protective devices, including but not limited to, nonmetallic control knobs, insulating fishpapers, adjustment and compartment covers/shields, and isolation resistor/capacitor networks. **Do not operate this instrument or permit it to be operated without all protective devices correctly installed and functioning. Servicers who defeat safety features or fail to perform safety checks may be liable for any resulting damage.**
 - b. Be sure that there are no cabinet openings through which an adult or child might be able to insert their fingers and contact a hazardous voltage. Such openings include, but are not limited to, (1) spacing between the picture tube and the cabinet mask, (2) excessively wide cabinet ventilation slots, and (3) an improperly fitted and/or incorrectly secured cabinet back cover.
 - c. **Antenna Cold Check** - With the instrument AC plug removed from any AC source, connect an electrical jumper across the two AC plug prongs. Place the instrument AC switch in the on position. Connect one lead of an ohmmeter to the AC plug prongs tied together and touch the other ohmmeter lead in turn to each tuner antenna input exposed terminal screw and, if applicable, to the coaxial connector. If the measured resistance is less than 1.0 megohm or greater than 5.2 megohm, an abnormality exists that must be corrected before the instrument is returned to the customer. Repeat this test with the instrument AC switch in the off position.
 - d. **Leakage Current Hot Check** - With the instrument completely reassembled, plug the

AC line cord directly into a 120 V AC outlet. (Do not use an isolation transformer during this test.) Use a leakage current tester or a metering system that complies with American National Standards Institute (ANSI) C101.1 Leakage Current for Appliances and Underwriters Laboratories (UL) 1410, (50.7). With the instrument AC switch first in the on position and then in the off position, measure from a known earth ground (metal water pipe, conduit, etc.) to all exposed metal parts of the instrument (antennas, handle brackets, metal cabinet, screw heads, metallic overlays, control shafts, etc.), especially any exposed metal parts that offer an electrical return path to the chassis. Any current measured must not exceed 0.5 milli-ampere. Reverse the instrument power cord plug in the outlet and repeat the test.

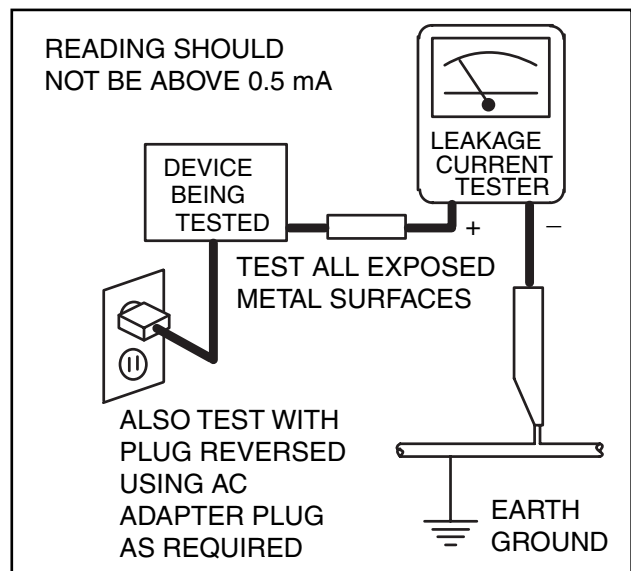

ANY MEASUREMENTS NOT WITHIN THE LIMITS SPECIFIED HEREIN INDICATE A POTENTIAL SHOCK HAZARD THAT MUST BE ELIMINATED BEFORE RETURNING THE INSTRUMENT TO THE CUSTOMER OR BEFORE CONNECTING THE ANTENNA OR ACCESSORIES.

- e. **X-Radiation and High Voltage Limits** - Because the picture tube is the primary potential source of X-radiation in solid-state TV receivers, it is specially constructed to prohibit X-radiation emissions. For continued X-radiation protection, the replacement picture tube must be the same type as the original.

Also, because the picture tube shields and mounting hardware perform an X-radiation protection function, they must be correctly in place. High voltage must be measured each time servicing is performed that involves B+, horizontal deflection or high voltage. Correct operation of the X-radiation protection circuits also must be reconfirmed each time they are serviced. (X-radiation protection circuits also may be called “horizontal disable” or “hold down.”) Read and apply the high voltage limits and, if the chassis is so equipped, the X-radiation protection circuit specifications given on instrument labels and in the Product Safety & X-Radiation Warning note on the service data chassis schematic. High voltage is maintained within specified limits by close tolerance safety-related components/adjustments in the high-voltage circuit. If high voltage exceeds specified limits, check each component specified on the chassis schematic and take corrective action.

2. Read and comply with all caution and safety-related notes on or inside the receiver cabinet, on the receiver chassis, or on the picture tube.
3. **Design Alteration Warning** - Do not alter or add to the mechanical or electrical design of this TV receiver. Design alterations and additions, including, but not limited to circuit modifications and the addition of items such as auxiliary audio and/or video output connections, might alter the safety characteristics of this receiver and create a hazard to the user. Any design alterations or additions will void the manufacturer's warranty and may make you, the servicer, responsible for personal injury or property damage resulting therefrom.
4. **Picture Tube Implosion Protection Warning** - The picture tube in this receiver employs integral implosion protection. For continued implosion protection, replace the picture tube only with one of the same type number. Do not remove, install, or otherwise handle the picture tube in any manner without first putting on shatterproof goggles equipped with side shields. People not so equipped must be kept safely away while picture tubes are handled. Keep the picture tube away from your body. Do not handle the picture tube by its neck. Some “in-line” picture tubes are equipped with a permanently attached deflection yoke; because of potential hazard, do not try to remove such “permanently attached” yokes from the picture tube.
5. **Hot Chassis Warning** -
 - a. Some TV receiver chassis are electrically connected directly to one conductor of the AC power cord and maybe safety-serviced without

an isolation transformer only if the AC power plug is inserted so that the chassis is connected to the ground side of the AC power source. To confirm that the AC power plug is inserted correctly, with an AC voltmeter, measure between the chassis and a known earth ground. If a voltage reading in excess of 1.0V is obtained, remove and reinsert the AC power plug in the opposite polarity and again measure the voltage potential between the chassis and a known earth ground.

- b. Some TV receiver chassis normally have 85V AC(RMS) between chassis and earth ground regardless of the AC plug polarity. This chassis can be safety-serviced only with an isolation transformer inserted in the power line between the receiver and the AC power source, for both personnel and test equipment protection.
 - c. Some TV receiver chassis have a secondary ground system in addition to the main chassis ground. This secondary ground system is not isolated from the AC power line. The two ground systems are electrically separated by insulation material that must not be defeated or altered.
6. Observe original lead dress. Take extra care to assure correct lead dress in the following areas: a. near sharp edges, b. near thermally hot parts-be sure that leads and components do not touch thermally hot parts, c. the AC supply, d. high voltage, and, e. antenna wiring. Always inspect in all areas for pinched, out of place, or frayed wiring. Check AC power cord for damage.
 7. Components, parts, and/or wiring that appear to have overheated or are otherwise damaged should be replaced with components, parts, or wiring that meet original specifications. Additionally, determine the cause of overheating and/or damage and, if necessary, take corrective action to remove any potential safety hazard.
 8. **Product Safety Notice** - Some electrical and mechanical parts have special safety-related characteristics which are often not evident from visual inspection, nor can the protection they give necessarily be obtained by replacing them with components rated for higher voltage, wattage, etc.. Parts that have special safety characteristics are identified by a  on schematics and in parts lists. Use of a substitute replacement that does not have the same safety characteristics as the recommended replacement part might create shock, fire, and/or other hazards. The product's safety is under review continuously and new instructions are issued whenever appropriate. Prior to shipment from the factory, our products are strictly inspected to confirm they comply with the recognized product safety and electrical codes

of the countries in which they are to be sold. However, in order to maintain such compliance, it is equally important to implement the following precautions when a set is being serviced.

Precautions during Servicing

- A.** Parts identified by the **▲** symbol are critical for safety.
Replace only with part number specified.
- B.** In addition to safety, other parts and assemblies are specified for conformance with regulations applying to spurious radiation. These must also be replaced only with specified replacements.
Examples: RF converters, RF cables, noise blocking capacitors, and noise blocking filters, etc.
- C.** Use specified internal wiring. Note especially:
 - 1) Wires covered with PVC tubing
 - 2) Double insulated wires
 - 3) High voltage leads
- D.** Use specified insulating materials for hazardous live parts. Note especially:
 - 1) Insulation Tape
 - 2) PVC tubing
 - 3) Spacers
 - 4) Insulators for transistors.
- E.** When replacing AC primary side components (transformers, power cord, etc.), wrap ends of wires securely about the terminals before soldering.
- F.** Observe that the wires do not contact heat producing parts (heat sinks, oxide metal film resistors, fusible resistors, etc.)
- G.** Check that replaced wires do not contact sharp edged or pointed parts.
- H.** When a power cord has been replaced, check that 5~6 kg of force in any direction will not loosen it.
- I.** Also check areas surrounding repaired locations.
- J.** Be careful that foreign objects (screws, solder droplets, etc.) do not remain inside the set.
- K.** Crimp type wire connector
When replacing the power transformer in sets where the connections between the power cord and power transformer primary lead wires are performed using crimp type connectors, in order to prevent shock hazards, perform carefully and precisely the following steps.
Replacement procedure
 - 1) Remove the old connector by cutting the wires at a point close to the connector.
Important: Do not re-use a connector (discard it).

- 2) Strip about 15 mm of the insulation from the ends of the wires. If the wires are stranded, twist the strands to avoid frayed conductors.
 - 3) Align the lengths of the wires to be connected. Insert the wires fully into the connector.
 - 4) Use the crimping tool to crimp the metal sleeve at the center position. Be sure to crimp fully to the complete closure of the tool.
- L.** When connecting or disconnecting the DVD/VCR connectors, first, disconnect the AC plug from the AC supply socket.

Safety Check after Servicing

Examine the area surrounding the repaired location for damage or deterioration. Observe that screws, parts and wires have been returned to original positions. Afterwards, perform the following tests and confirm the specified values in order to verify compliance with safety standards.

1. Clearance Distance

When replacing primary circuit components, confirm specified clearance distance (d) and (d') between soldered terminals, and between terminals and surrounding metallic parts. (See Fig. 1)

Table 1: Ratings for selected area

AC Line Voltage	Region	Clearance Distance (d), (d')
110 to 130 V	U.S.A. or Canada	≥ 3.2 mm (0.126 inches)

Note: This table is unofficial and for reference only. Be sure to confirm the precise values.

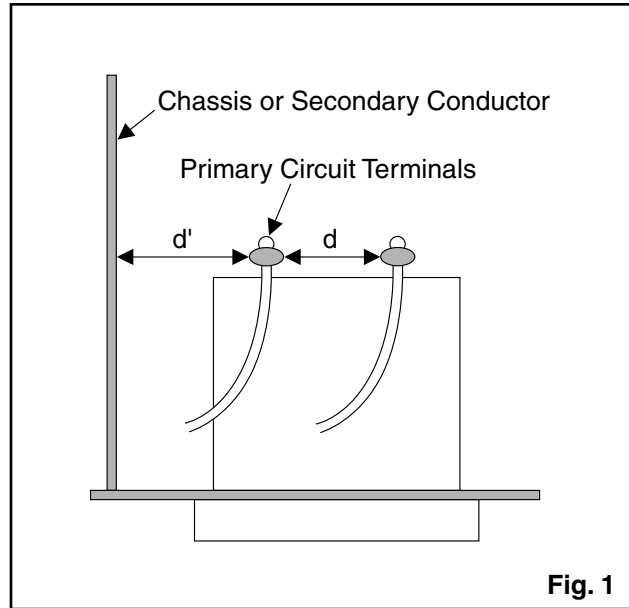

Fig. 1

2. Leakage Current Test

Confirm the specified (or lower) leakage current between B (earth ground, power cord plug prongs) and externally exposed accessible parts (RF terminals, antenna terminals, video and audio input and output terminals, microphone jacks, earphone jacks, etc.).

Measuring Method: (Power ON)

Insert load Z between B (earth ground, power cord plug prongs) and exposed accessible parts. Use an AC voltmeter to measure across both terminals of load Z. See Fig. 2 and following table.

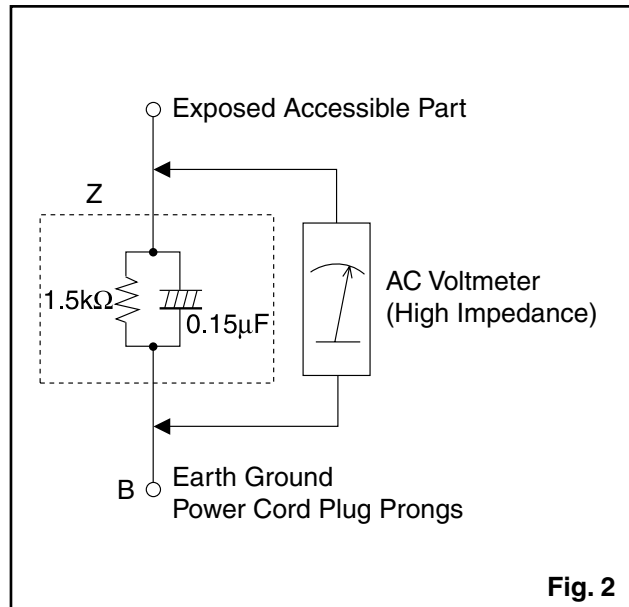

Fig. 2

Table 2: Leakage current ratings for selected areas

AC Line Voltage	Region	Load Z	Leakage Current (i)	Earth Ground (B) to:
110 to 130 V	U.S.A. or Canada	$0.15\mu\text{F}$ CAP. & $1.5\text{k}\Omega$ RES. Connected in parallel	$i \leq 0.5$ mA rms	Exposed accessible parts

Note: This table is unofficial and for reference only. Be sure to confirm the precise values.

STANDARD NOTES FOR SERVICING

Circuit Board Indications

1. The output pin of the 3 pin Regulator ICs is indicated as shown.

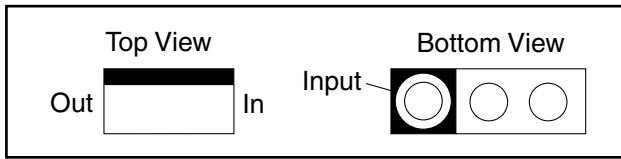

2. For other ICs, pin 1 and every fifth pin are indicated as shown.

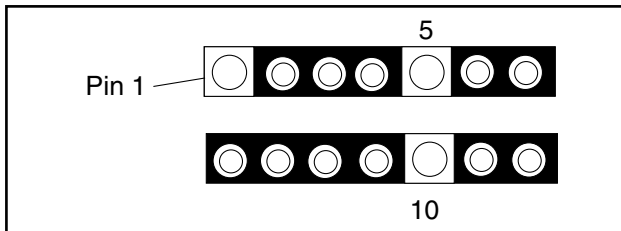

3. The 1st pin of every male connector is indicated as shown.

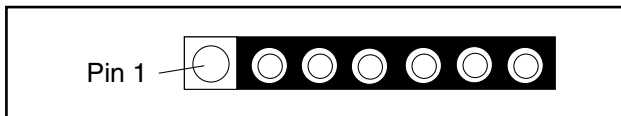

Instructions for Connectors

1. When you connect or disconnect the FFC (Flexible Foil Connector) cable, be sure to first disconnect the AC cord.
2. FFC (Flexible Foil Connector) cable should be inserted parallel into the connector, not at an angle.

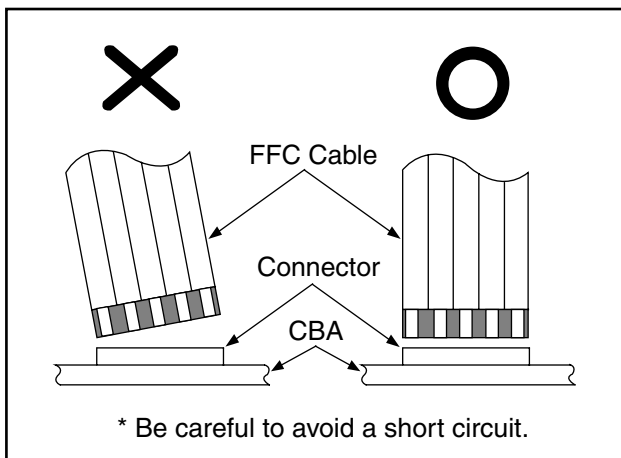

Pb (Lead) Free Solder

Pb free mark will be found on PCBs which use Pb free solder. (Refer to figure.) For PCBs with Pb free mark, be sure to use Pb free solder. For PCBs without Pb free mark, use standard solder.

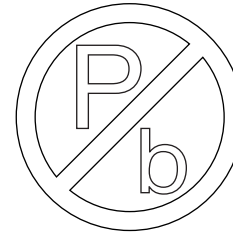

Pb free mark

How to Remove / Install Flat Pack-IC

1. Removal

With Hot-Air Flat Pack-IC Desoldering Machine:

1. Prepare the hot-air flat pack-IC desoldering machine, then apply hot air to the Flat Pack-IC (about 5 to 6 seconds). (Fig. S-1-1)

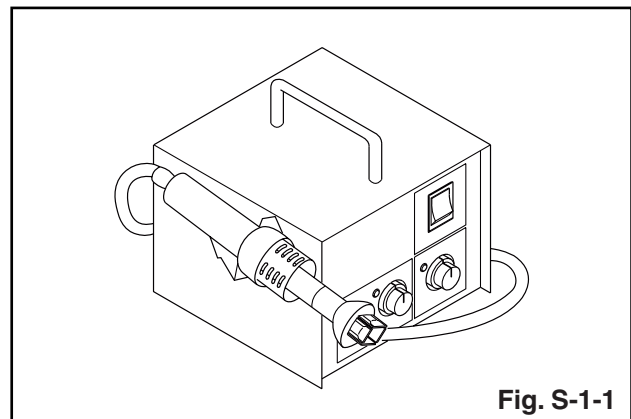

Fig. S-1-1

2. Remove the flat pack-IC with tweezers while applying the hot air.
3. Bottom of the flat pack-IC is fixed with glue to the CBA; when removing entire flat pack-IC, first apply soldering iron to center of the flat pack-IC and heat up. Then remove (glue will be melted). (Fig. S-1-6)
4. Release the flat pack-IC from the CBA using tweezers. (Fig. S-1-6)

CAUTION:

1. The Flat Pack-IC shape may differ by models. Use an appropriate hot-air flat pack-IC desoldering machine, whose shape matches that of the Flat Pack-IC.
2. Do not supply hot air to the chip parts around the flat pack-IC for over 6 seconds because damage to the chip parts may occur. Put masking tape

around the flat pack-IC to protect other parts from damage. (Fig. S-1-2)

3. The flat pack-IC on the CBA is affixed with glue, so be careful not to break or damage the foil of each pin or the solder lands under the IC when removing it.

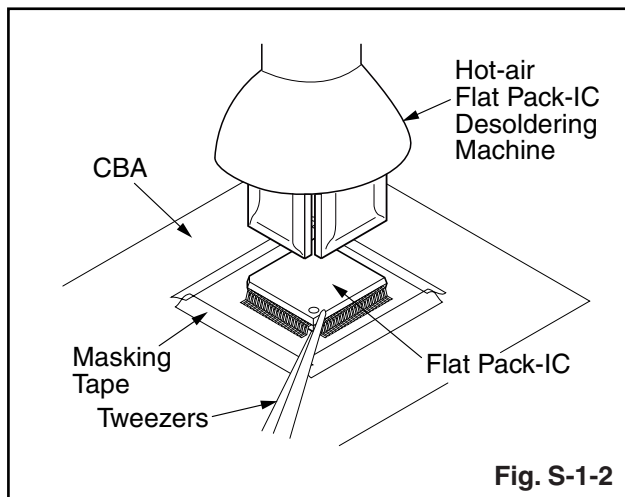

With Soldering Iron:

1. Using desoldering braid, remove the solder from all pins of the flat pack-IC. When you use solder flux which is applied to all pins of the flat pack-IC, you can remove it easily. (Fig. S-1-3)

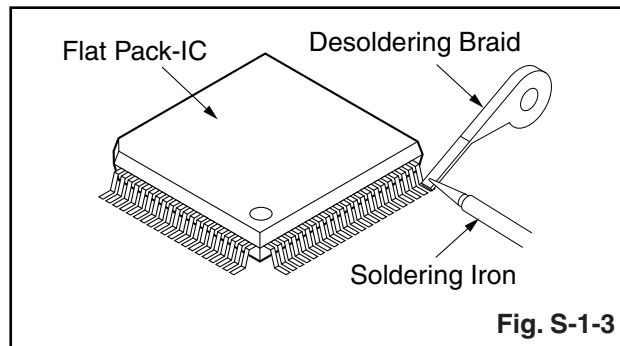

2. Lift each lead of the flat pack-IC upward one by one, using a sharp pin or wire to which solder will not adhere (iron wire). When heating the pins, use a fine tip soldering iron or a hot air desoldering machine. (Fig. S-1-4)

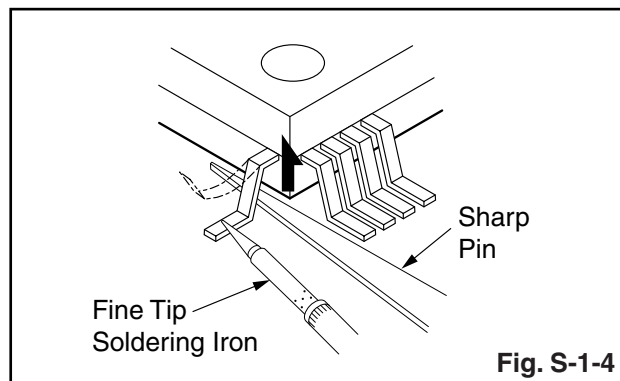

3. Bottom of the flat pack-IC is fixed with glue to the CBA; when removing entire flat pack-IC, first apply soldering iron to center of the flat pack-IC and heat up. Then remove (glue will be melted). (Fig. S-1-6)
4. Release the flat pack-IC from the CBA using tweezers. (Fig. S-1-6)

With Iron Wire:

1. Using desoldering braid, remove the solder from all pins of the flat pack-IC. When you use solder flux which is applied to all pins of the flat pack-IC, you can remove it easily. (Fig. S-1-3)
2. Affix the wire to a workbench or solid mounting point, as shown in Fig. S-1-5.
3. While heating the pins using a fine tip soldering iron or hot air blower, pull up the wire as the solder melts so as to lift the IC leads from the CBA contact pads as shown in Fig. S-1-5.
4. Bottom of the flat pack-IC is fixed with glue to the CBA; when removing entire flat pack-IC, first apply soldering iron to center of the flat pack-IC and heat up. Then remove (glue will be melted). (Fig. S-1-6)
5. Release the flat pack-IC from the CBA using tweezers. (Fig. S-1-6)

Note: When using a soldering iron, care must be taken to ensure that the flat pack-IC is not being held by glue. When the flat pack-IC is removed from the CBA, handle it gently because it may be damaged if force is applied.

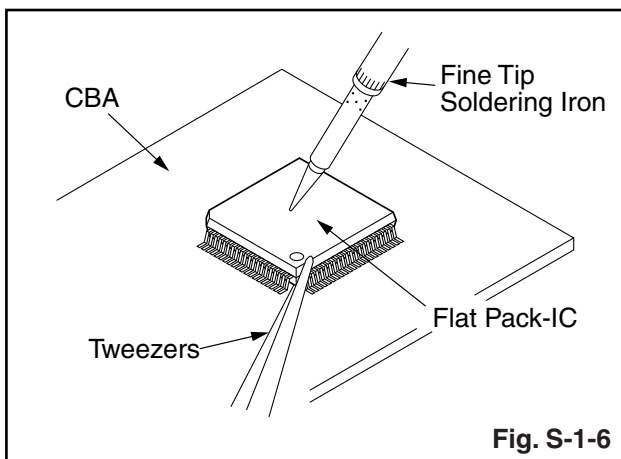
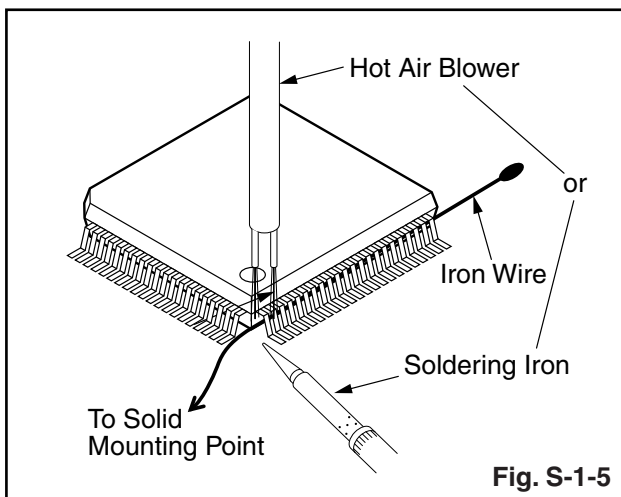

2. Installation

1. Using desoldering braid, remove the solder from the foil of each pin of the flat pack-IC on the CBA so you can install a replacement flat pack-IC more easily.
2. The "●" mark on the flat pack-IC indicates pin 1. (See Fig. S-1-7.) Be sure this mark matches the 1 on the PCB when positioning for installation. Then presolder the four corners of the flat pack-IC. (See Fig. S-1-8.)
3. Solder all pins of the flat pack-IC. Be sure that none of the pins have solder bridges.

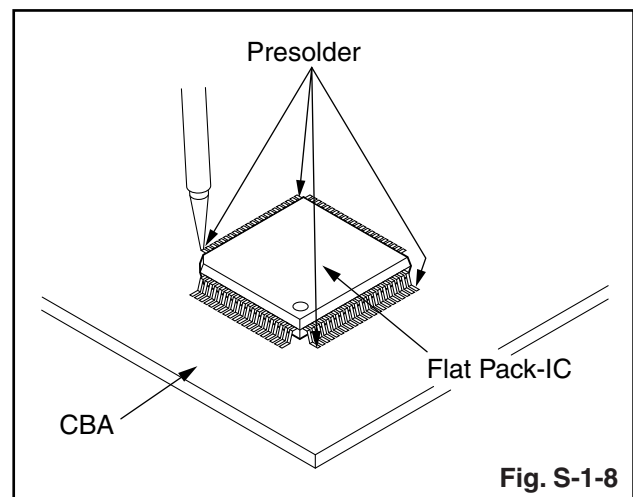
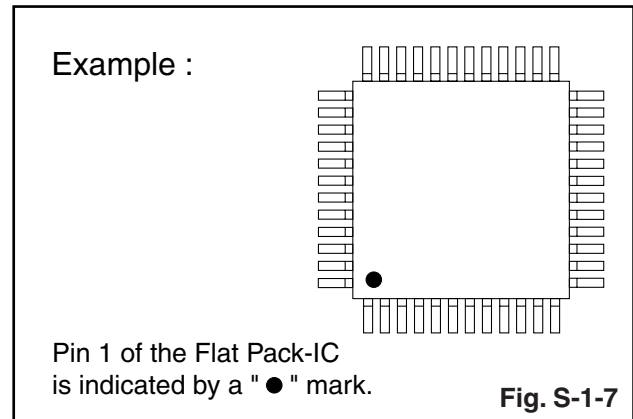

Instructions for Handling Semi-conductors

Electrostatic breakdown of the semi-conductors may occur due to a potential difference caused by electrostatic charge during unpacking or repair work.

1. Ground for Human Body

Be sure to wear a grounding band (1 M Ω) that is properly grounded to remove any static electricity that may be charged on the body.

2. Ground for Workbench

Be sure to place a conductive sheet or copper plate with proper grounding (1 M Ω) on the workbench or other surface, where the semi-conductors are to be placed. Because the static electricity charge on clothing will not escape through the body grounding band, be careful to avoid contacting semi-conductors with your clothing.

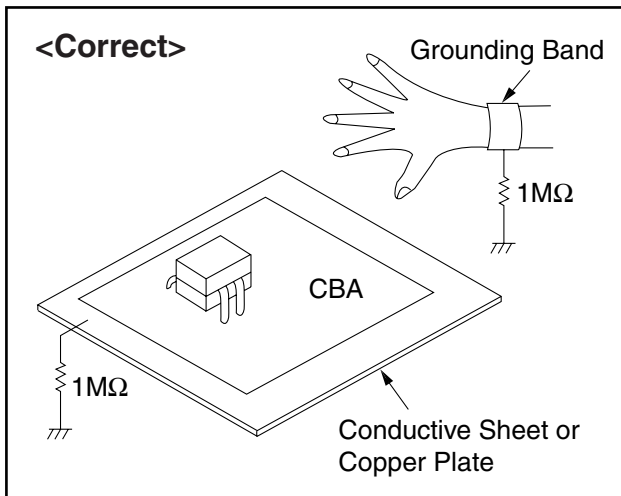
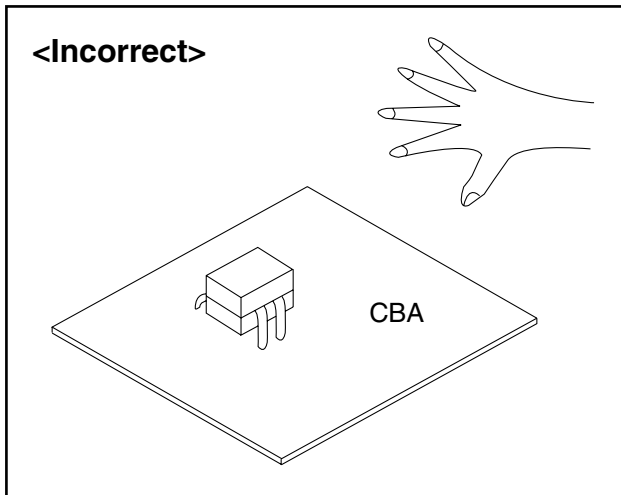

PREPARATION FOR SERVICING

How to Enter the Service Mode

Caution 1:

- Optical sensors system are used for Tape Start and End Sensor on this equipment. Read this page carefully and prepare as described on this page before starting to service; otherwise, the unit may operate unexpectedly.

Preparing 1:

- Cover Q202 (START SENSOR) and Q201 (END SENSOR) with Insulation Tape or enter the service mode to activate Sensor Inhibition automatically.

Note: Avoid playing, rewinding or fast forwarding the tape to its beginning or end, because both Tape End Sensors are not active.

How to Enter the Service Mode

- Turn power on.
- Use service remote control unit and press [DISC MENU] button. (See page 1-7-1.)
- When entering the service mode, one of the number (1, 2 or 4) will display at corners of the screen.
- During the service mode, electrical adjustment mode can be selected by remote control key. (Service remote control unit).

Details are as follows.

Key	Adjustment Mode
PICTURE	Picture adjustment mode: Press the [PICTURE] button to change from BRT (Bright), *CNT (Contrast), *COL (Color), *TNT (Tint), *V-TNT (V-Tint) and *SHP (Sharpness). Press [CH ▲/▼] buttons to display Initial Value. *Marked items are not necessary to adjust normally.
0	C-Trap adjustment: See adjustment instructions page 1-7-2. Y DL Time TV/Y DL Time EXT/Y SW LPF/Black Stretch Off/ Black Stretch CONT/C. Angle data values setting: See adjustment instructions page 1-7-3.
1	No need to use.
2	H f ₀ adjustment mode: See adjustment instructions page 1-7-5.
3	No need to use.
4	Auto record mode: Perform recording (15 Sec.) --> Stop --> Rewind (Zero return) automatically.

Key	Adjustment Mode
5	Head switching position adjustment: See adjustment instructions page 1-7-8.
6	No need to use.
7	Purity check mode: Shows Red, Green, Blue or White cyclically on the screen each time the [7] button is pressed.
8	H. Position adjustment: See adjustment instructions page 1-7-7.
9	V. Shift/V.Size adjustment: See adjustment instructions page 1-7-7.
VOL ▲	CD-VOL/DVD-BRT/DVD-CNT/DVD-SHARP data values setting: See adjustment instructions page 1-7-4.
VOL ▼	Cut-off adjustment: See adjustment instructions page 1-7-5. White balance adjustment: See adjustment instructions page 1-7-6.

Caution 2:

- The deck mechanism assembly is mounted on the Main CBA directly, and SW1211 (REC-SAFETY SW) is mounted on the Main CBA. When deck mechanism assembly is removed from the Main CBA due to servicing, this switch can not be operated automatically.

Preparing 2:

- To eject the tape, press the [STOP/EJECT] button on the unit (or Remote Control).
- When you want to record during the Service mode, press the [Rec] button while depressing SW1211 (REC-SAFETY SW) on the Main CBA.

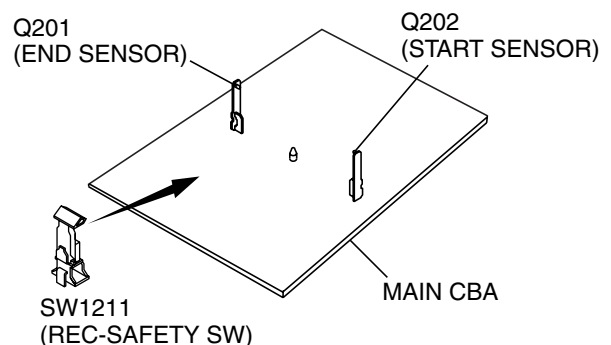

CABINET DISASSEMBLY INSTRUCTIONS

1. Disassembly Flowchart

This flowchart indicates the disassembly steps for the cabinet parts, and the CBA in order to gain access to item(s) to be serviced. When reassembling, follow the steps in reverse order. Bend, route and dress the cables as they were.

CAUTION!

When removing the CRT, be sure to discharge the Anode Lead of the CRT with the CRT Ground Wire before removing the Anode Cap.

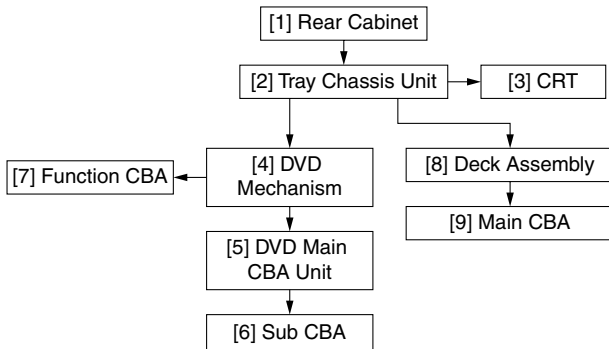

2. Disassembly Method

Step/ Loc. No.	Part	Removal		
		Fig. No.	Remove/*Unhook/ Unlock/Release/ Unplug/Unclamp/ Desolder	Note
[1]	Rear Cabinet	D1	4(S-1), (S-2), 2(S-3)	---
[2]	Tray Chassis Unit	D2 D3 D5	Anode Cap, *CN2501, CRT CBA, *CN1601, *CN1802, *CN2571, *CN2801	1
[3]	CRT	D3 D5	4(S-4)	---
[4]	DVD Mechanism	D2 D4 D5	4(S-5), Wire Holder C, 2(S-6), Loader Cover, *CN201, *CN301	2, 3
[5]	DVD Main CBA Unit	D2 D4 D5	*CN1, *CN2	---
[6]	Sub CBA	D2 D5	5(S-7), Loader PCB Holder, *CN1301, *CN1602	---
[7]	Function CBA	D2 D5	(S-8), *CN2401	---

Step/ Loc. No.	Part	Removal		
		Fig. No.	Remove/*Unhook/ Unlock/Release/ Unplug/Unclamp/ Desolder	Note
[8]	Deck Assembly	D2 D5	3(S-9), Top Shield, 7(S-10), (S-11), (S-12), *CL1201, *CL1401, *CL1402, *CL403	4
[9]	Main CBA	D2	5(S-13)	---

↓ (1) ↓ (2) ↓ (3) ↓ (4) ↓ (5)

Note:

- (1) Order of steps in procedure. When reassembling, follow the steps in reverse order. These numbers are also used as the Identification (location) No. of parts in figures.
- (2) Parts to be removed or installed.
- (3) Fig. No. showing procedure of part location
- (4) Identification of parts to be removed, unhooked, unlocked, released, unplugged, unclamped, or desoldered.
P = Spring, L = Locking Tab, S = Screw, CN = Connector
* = Unhook, Unlock, Release, Unplug, or Desolder
e.g. 2(S-2) = two Screws (S-2),
2(L-2) = two Locking Tabs (L-2)
- (5) Refer to the following "Reference Notes in the Table".

Reference Notes in the Table

CAUTION!

When removing the CRT, be sure to discharge the Anode Lead of the CRT with the CRT Ground Wire before removing the Anode Cap.

1. **CAUTION 1:** Discharge the Anode Lead of the CRT with the CRT Ground Wire before removing the Anode Cap.

Disconnect the following: Anode Cap, CN2501, CRT CBA, CN1601, CN1802, CN2571 and CN2801. Then remove Tray Chassis Unit.

2. **CAUTION 2:** Electrostatic breakdown of the laser diode in the optical system block may occur as a potential difference caused by electrostatic charge accumulated on cloth, human body etc., during unpacking or repair work.
To avoid damage of pickup follow next procedures.

- 1) Disconnect Connector (CN301) on the DVD Main CBA Unit.
- 2) Short the three short lands of FPC cable with solder before removing the FFC cable (CN201) from it. If you disconnect the FFC cable (CN201), the laser diode of pickup will be destroyed. (Fig. D4)

- 3) Remove four screws (S-5) and Wire Holder C, and remove DVD Mechanism.

3. **CAUTION 3:** When reassembling, confirm the FFC cable (CN201) is connected completely. Then remove the solder from the three short lands of FPC cable. (Fig. D4)

4. Remove three screws (S-9) and remove Top Shield. Remove screws 7(S-10), (S-11) and (S-12). Then, desolder connectors (CL1201, CL1401, CL1402, CL403) and lift up the Deck Assembly.

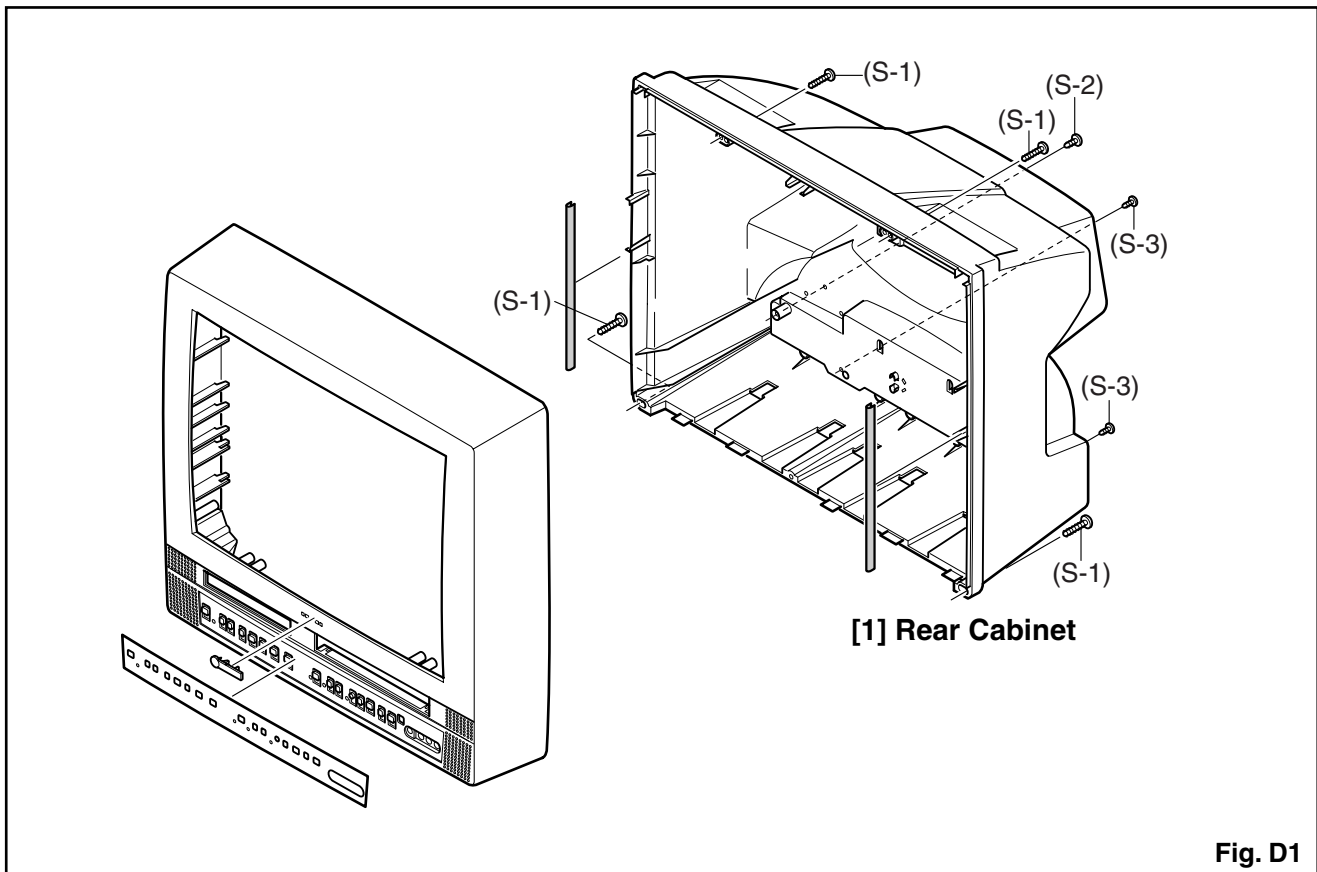

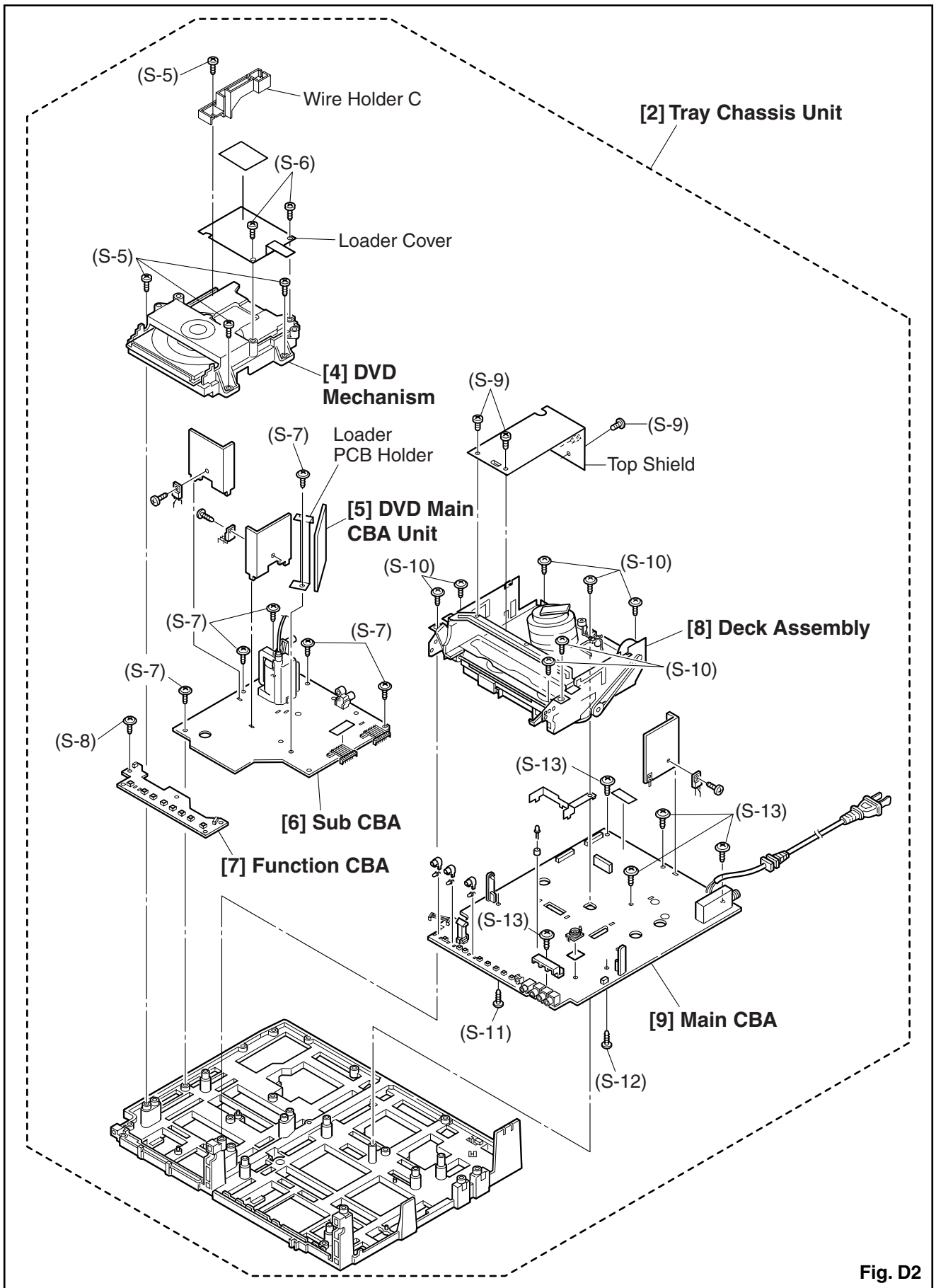

Fig. D2

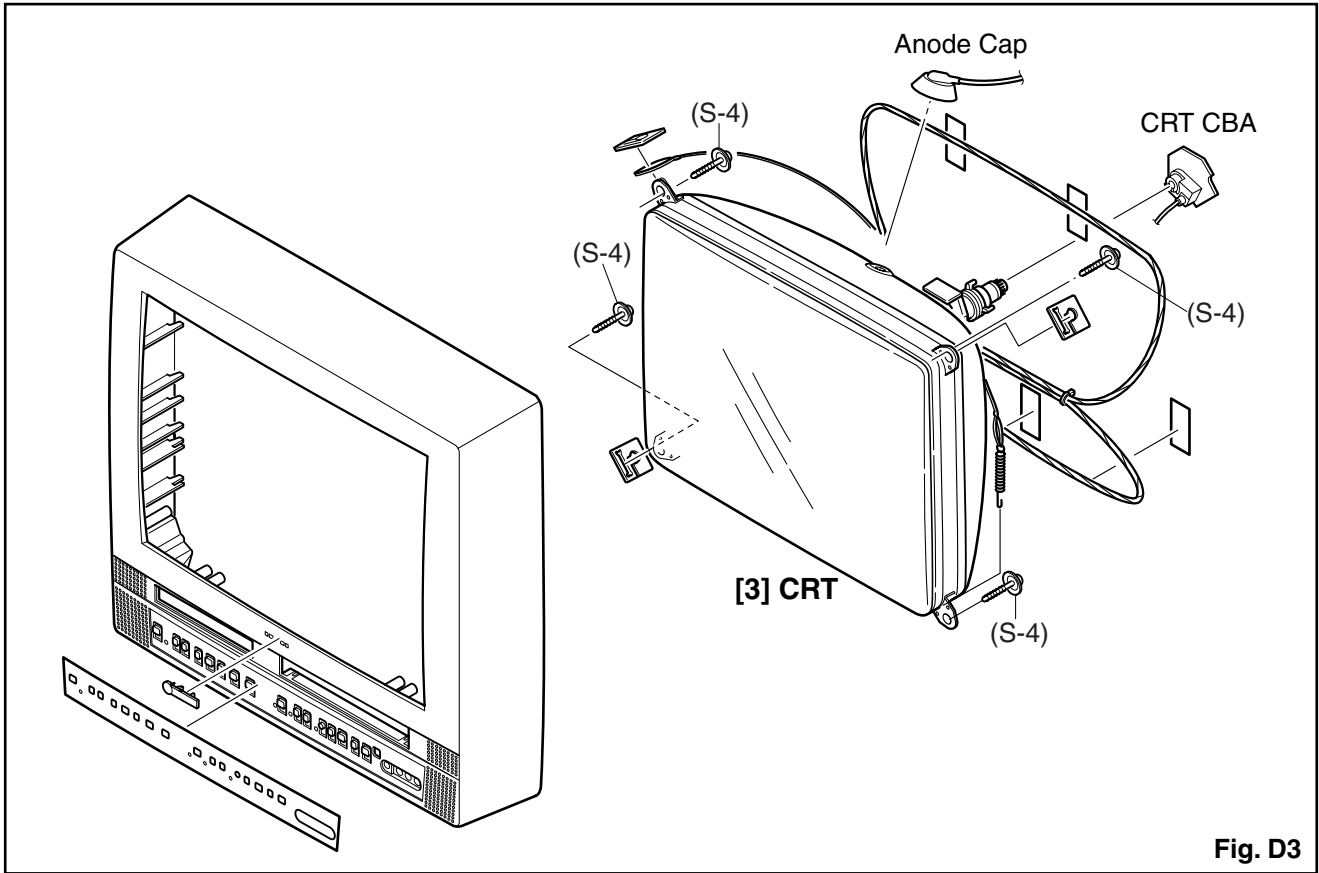

Fig. D3

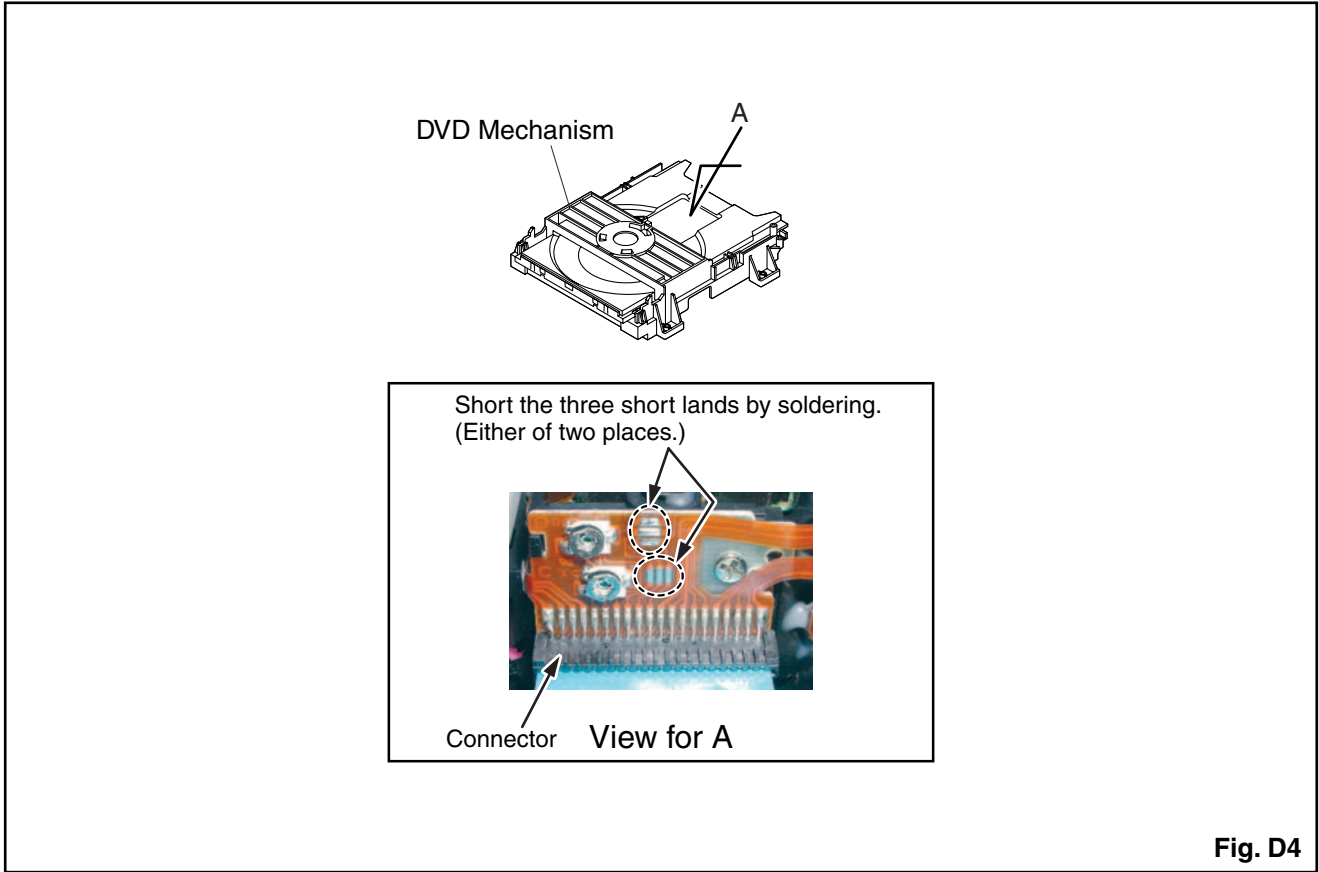

Fig. D4

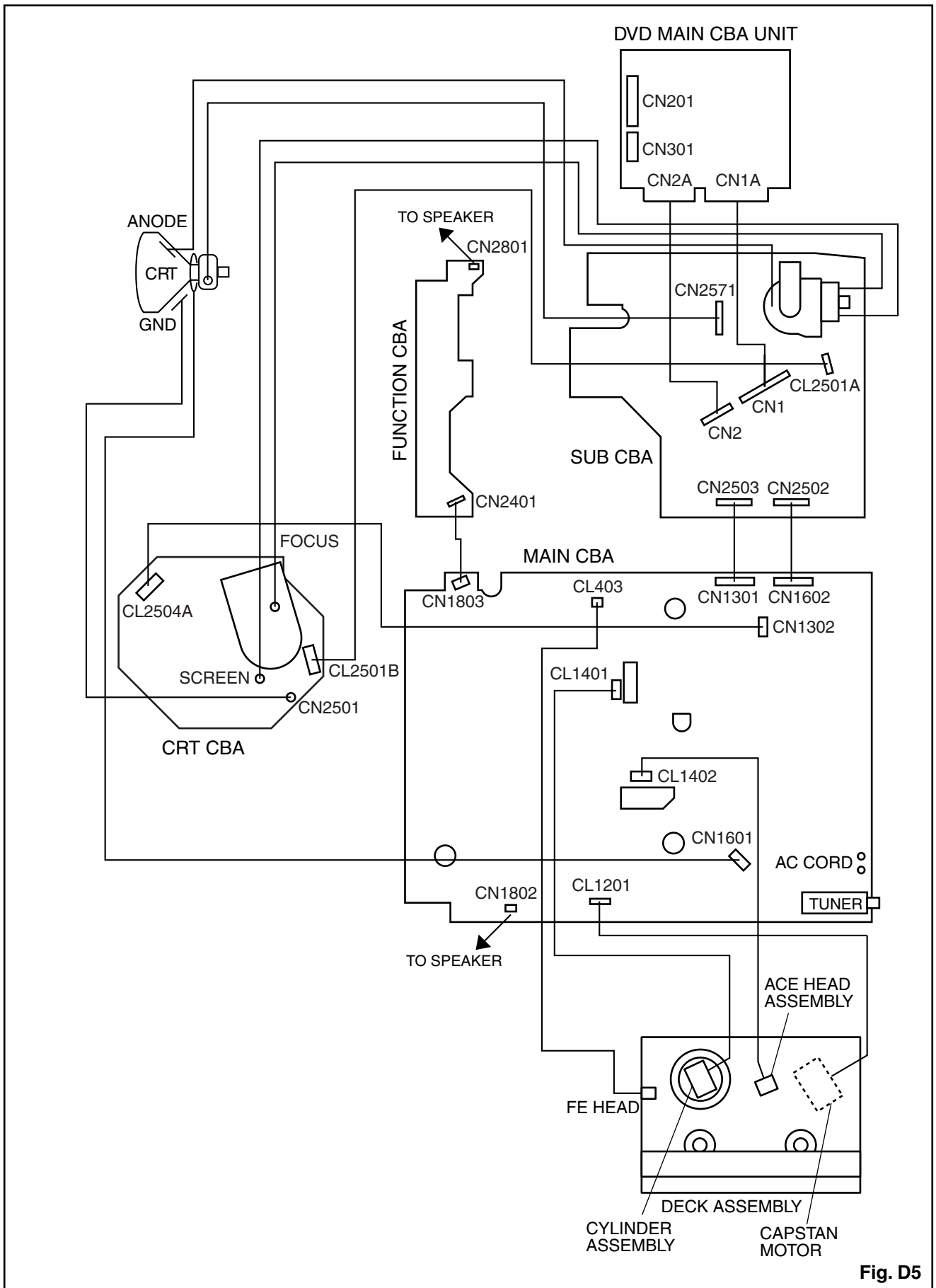

Fig. D5

ELECTRICAL ADJUSTMENT INSTRUCTIONS

General Note: “CBA” is abbreviation for “Circuit Board Assembly.”

Note: Electrical adjustments are required after replacing circuit components and certain mechanical parts. It is important to perform these adjustments only after all repairs and replacements have been completed. Also, do not attempt these adjustments unless the proper equipment is available.

Test Equipment Required

1. NTSC Pattern Generator (Color Bar W/White Window, Red Color, Dot Pattern, Gray Scale, Monoscope, Multi-Burst)
2. AC Milli Voltmeter (RMS)
3. Alignment Tape (FL8A, FL8N), Blank Tape
4. DC Voltmeter
5. Oscilloscope: Dual-trace with 10:1 probe, V-Range: 0.001~50 V/Div, F-Range: DC~AC-60 MHz
6. Frequency Counter
7. Plastic Tip Driver
8. Color Analyzer

How to make service remote control unit:

1. Prepare normal remote control unit (Part No. NE209UD). Remove 4 screws from the back lid (Fig. 1-1).

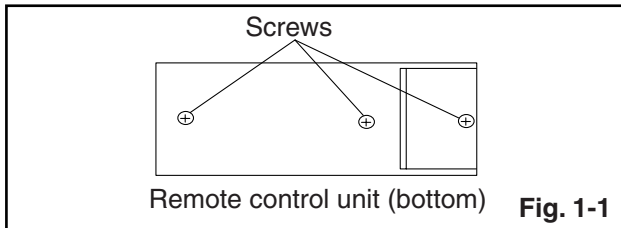

2. Cut off pin 10 of the remote control microprocessor and short circuit pins 10 and 17 of the microprocessor with a jumper wire

How to Set up the Service mode:

Service mode:

1. Use the service remote control unit.
2. Turn the power on. (Use main power on the TV unit.)
3. To enter the TV mode, press [CH ▲ / ▼] buttons on the TV unit.
4. Press [DISC MENU] button on the service remote control unit. Version of micro computer will display on the CRT. (Ex: 057-001)

X-Ray Protection Test

X-Ray protection test should be done when replacing any parts of this chassis.

1. Short both ends of R2592 (on Sub CBA).
2. Confirm that the main power turns off.
3. If the main power does not turn off, then replace the following parts (D2591, Q2591, R2592, R2593, R2594 and IC1201).
4. Perform steps 1 to 3 again.

1. DC 114V (+B) Adjustment

Purpose: To obtain correct operation.

Symptom of Misadjustment: The picture is dark and unit does not operate correctly.

Test Point	Adj. Point	Mode	Input
TP2501(+B) J2550(GND)	VR1601	---	---
Tape	M. EQ.	Spec.	
---	DC Voltmeter	+114±1.0 V DC	

Note: TP2501(+B), J2550(GND) --- Sub CBA, VR1601 --- Main CBA

1. Connect the unit to AC Power Outlet.
2. Connect DC Volt Meter to TP2501(+B) and J2550(GND).
3. Adjust VR1601 so that the voltage of TP2501(+B) becomes +114±1.0 V DC.

2. Setting for CONTRAST, COLOR, TINT, V-TINT and SHARP Data Values

General

1. Enter the Service mode. (See page 1-7-1.)
2. Press [PICTURE] button on the service remote control unit. Display changes “BRT,” “CNT,” “COL,” “TNT,” “V-TNT,” and “SHP” cyclically when [PICTURE] button is pressed.

CONTRAST (CNT)

1. Press [PICTURE] button on the service remote control unit. Then select “CONTRAST (CNT)” display.
2. Press [CH ▲ / ▼] buttons on the service remote control unit so that the value of “CONTRAST (CNT)” becomes 84.

COLOR (COL)

1. Press [PICTURE] button on the service remote control unit. Then select “COLOR (COL)” display.
2. Press [CH ▲ / ▼] buttons on the service remote control unit so that the value of “COLOR (COL)” becomes 58.

TINT (TNT)

1. Press [PICTURE] button on the service remote control unit. Then select “TINT (TNT)” display.
2. Press [CH ▲ / ▼] buttons on the service remote control unit so that the value of “TINT (TNT)” becomes 56.

V-TINT (V-TNT)

1. Press [PICTURE] button on the service remote control unit. Then select “V-TINT (V-TNT)” display.
2. Press [CH ▲ / ▼] buttons on the service remote control unit so that the value of “V-TINT (V-TNT)” becomes 56.

SHARPNESS (SHP)

1. Press [PICTURE] button on the service remote control unit. Then select “SHARPNESS (SHP)” display.
2. Press [CH ▲ / ▼] buttons on the service remote control unit so that the value of “SHARPNESS (SHP)” becomes 46.

Note: BRIGHT data value does not need to be adjusted at this moment.

3. C-Trap Adjustment

Purpose: To get minimum leakage of the color signal carrier.

Symptom of Misadjustment: If C-Trap Adjustment is incorrect, stripes will appear on the screen.

Test Point	Adj. Point	Mode	Input
TP1301 (B-OUT)	[CH ▲ / ▼] buttons	---	Color Bar
Tape	M. EQ.	Spec.	
---	Oscilloscope Pattern Generator	---	

Figure

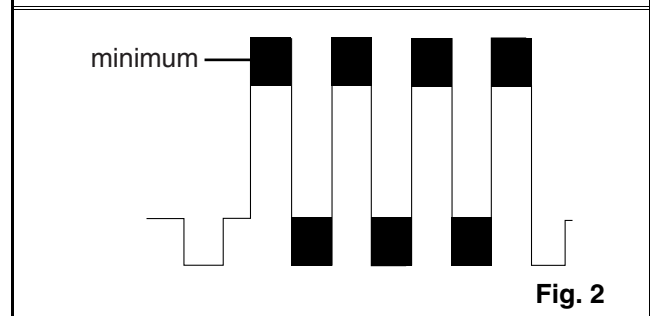

Note: TP1301(B-OUT) --- Main CBA

1. Connect oscilloscope to TP1301.
2. Input a color bar signal from RF input. Enter the Service mode. (See page 1-7-1.)
3. Press [0] button on the remote control unit and select C-TRAP mode. (Fig. 3)
4. Press [CH ▲ / ▼] buttons on the remote control unit so that the carrier leakage B-Out (3.58 MHz) value becomes minimum on the oscilloscope.

4. Setting for Y DL Time TV, Y DL Time EXT, Y SW LPF, Black Stretch Off, Black Stretch CONT and C. Angle Data Values

- Enter the Service mode. (See page 1-7-1.)
- Y DL Time TV Adjustment:** Press [0] button on the service remote control unit twice to show “D-T TV” on the display.

Y DL Time EXT Adjustment: Press [0] button on the service remote control unit three times to show “D-T EXT” on the display.

Y SW LPF Adjustment: Press [0] button on the service remote control unit four times to show “Y SW” on the display.

Black Stretch Off Adjustment: Press [0] button on the service remote control unit five times to show “B-S” on the display.

Black Stretch CONT Adjustment: Press [0] button on the service remote control unit six times to show “BS2” on the display.

C. Angle Adjustment: Press [0] button on the service remote control unit seven times to show “C-ANG” on the display.
- Y DL Time TV Adjustment:** Select “2” by pressing [CH ▲ / ▼] buttons on the service remote control.

Y DL Time EXT Adjustment: Select “3” by pressing [CH ▲ / ▼] buttons on the service remote control.

Y SW LPF Adjustment: Select “0” by pressing [CH ▲ / ▼] buttons on the service remote control.

Black Stretch Off Adjustment: Select “OFF” by pressing [CH ▲ / ▼] buttons on the service remote control.

Black Stretch CONT Adjustment: Select “0” by pressing [CH ▲ / ▼] buttons on the service remote control.

C. Angle Adjustment: Select “103” by pressing [CH ▲ / ▼] buttons on the service remote control.

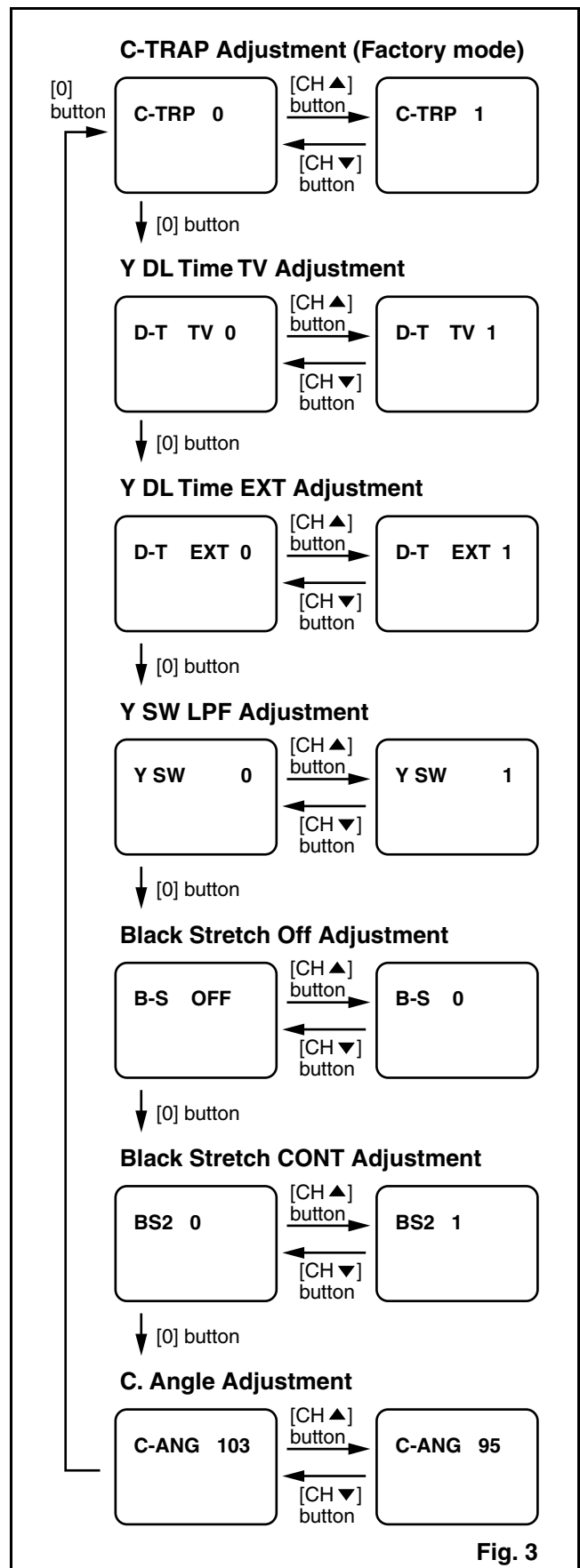

Fig. 3

5. Setting for CD-VOL, DVD-BRT, DVD-CNT and DVD-SHARP Data Values

- Enter the Service mode. (See page 1-7-1.)
- CD-VOL Adjustment:** Press [VOL ▲] button on the service remote control unit once to show “CD VOL” on the display.

DVD-BRT Adjustment: Press [VOL ▲] button on the service remote control unit twice to show “DVD BRT” on the display.

DVD-CNT Adjustment: Press [VOL ▲] button on the service remote control unit three times to show “DVD CNT” on the display.

DVD-SHARP Adjustment: Press [VOL ▲] button on the service remote control unit four times to show “DVD SHP” on the display.
- CD-VOL Adjustment:** Select “7” by pressing [CH ▲ / ▼] buttons on the service remote control.

DVD-BRT Adjustment: Select “14” by pressing [CH ▲ / ▼] buttons on the service remote control.

DVD-CNT Adjustment: Select “0” by pressing [CH ▲ / ▼] buttons on the service remote control.

DVD-SHARP Adjustment: Select “3” by pressing [CH ▲ / ▼] buttons on the service remote control.

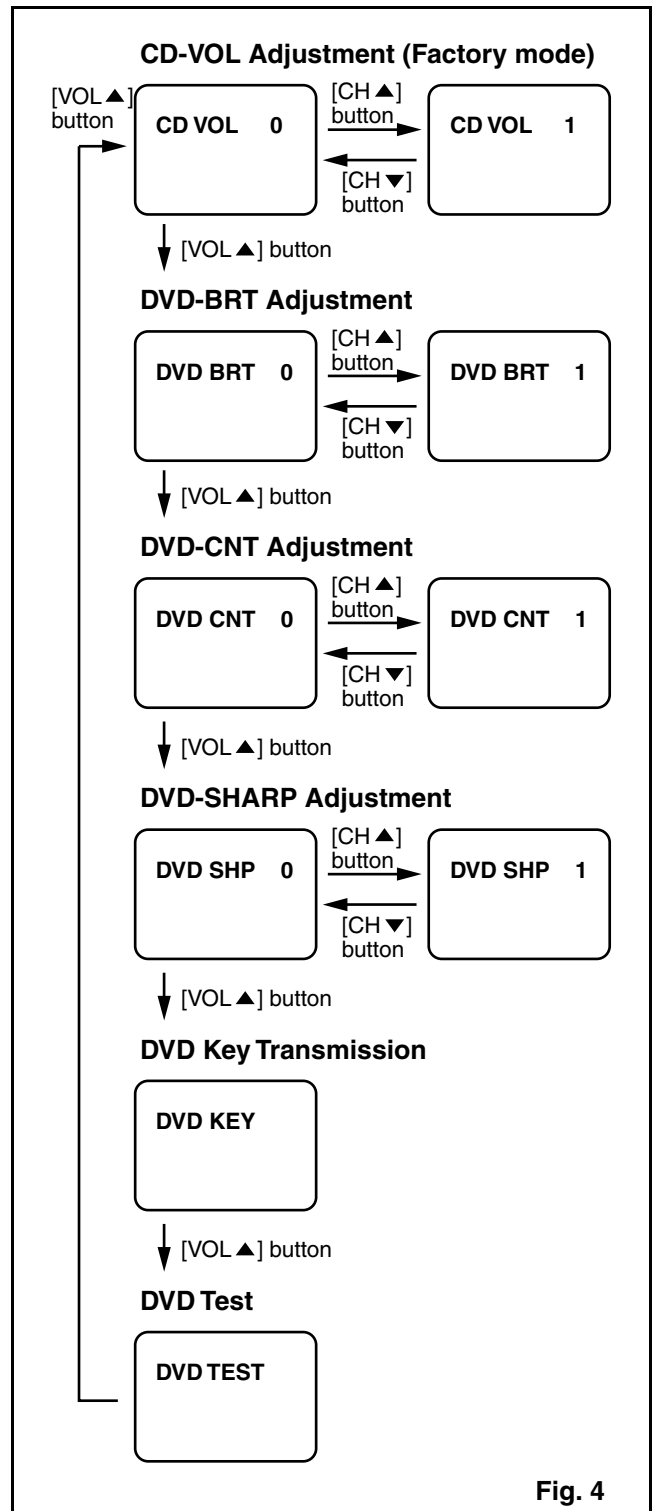

Fig. 4

6. H f₀ Adjustment

Purpose: To get correct horizontal position and size of screen image.

Symptom of Misadjustment: Horizontal position and size of screen image may not be properly displayed.

Test Point	Adj. Point	Mode	Input
R2583	[CH ▲ / ▼] buttons	Video	---
Tape	M. EQ.	Spec.	
---	Frequency Counter	15.734 kHz±300 Hz	

Note: R2583 --- Sub CBA

1. Connect frequency counter to R2583.
2. Operate the unit for at least 20 minutes.
3. Enter the Service mode. (See page 1-7-1.) Press [2] button on the remote control unit and select H-ADJ mode.
4. Press [CH ▲ / ▼] buttons on the remote control unit so that the display will change "0" to "7."
5. At this moment, choose display "0" to "7" when the frequency counter display is closest to 15.734 kHz ± 300 Hz.

7. Cut-off Adjustment

Purpose: To adjust the beam current of R, G, B, and screen voltage.

Symptom of Misadjustment: White color may be reddish, greenish or bluish.

Test Point	Adj. Point	Mode	Input
---	Screen-Control [CH ▲ / ▼] buttons	RF	Black Raster
Tape	M. EQ.	Spec.	
---	Pattern Generator	See Reference Notes below.	

Figure

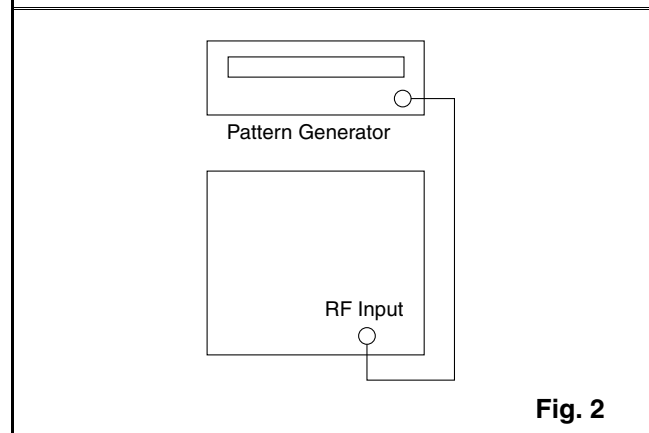

Fig. 2

Notes: Screen Control --- FBT (Sub CBA),
FBT = Fly Back Transformer,
Use the Remote Control Unit.

1. Degauss the CRT and allow the unit to operate for 20 minutes before starting the alignment.
2. Input the Black raster signal from RF input.
3. Enter the Service mode. (See page 1-7-1.)
4. Press the [VOL ▼] button.
(Press [VOL ▼] button then display will change "C/D", "7F" and Initial Setting.)
5. Choose CUT OFF/DRIVE mode then press [1] button. This adjustment mode is CUT OFF (R).
6. Increase the screen control so that the horizontal line just appears on the CRT.
7. Press the [CH ▲ / ▼] buttons until the horizontal line becomes white.
8. Choose CUT OFF/DRIVE mode then press [2] button. This adjustment mode is CUT OFF (G). Press [CH ▲ / ▼] buttons until the horizontal line becomes white.
9. Choose CUT OFF/DRIVE mode then press [3] button. This adjustment mode is CUT OFF (B). Press [CH ▲ / ▼] buttons until the horizontal line becomes white.

8. White Balance Adjustment

Purpose: To mix red, green and blue beams correctly for pure white.

Symptom of Misadjustment: White becomes bluish or reddish.

Test Point	Adj. Point	Mode	Input
Screen	[CH ▲ / ▼] buttons	RF	White Raster (APL 100%)
Tape	M. EQ.	Spec.	
---	Pattern Generator, Color analyzer	See below	

Figure

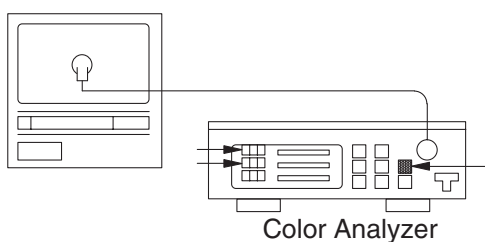

Fig. 6

Note: Use service remote control unit

- Operate the unit more than 20 minutes.
- Face the unit to the east. Degauss the CRT using a degaussing coil.
- Input the White Raster (APL 100%).
- Set the color analyzer to the CHROMA mode and after zero point calibration, bring the optical receptor to the center on the tube surface (CRT).
- Enter the Service mode. Press [VOL ▼] button on the service remote control unit and select "C/D" mode. (Display changes "C/D", "7F" and Initial Setting cyclically when [VOL ▼] button is pressed.)
- Press [4] button on the service remote control unit for Red adjustment. Press [5] button on the service remote control unit for Blue adjustment.
- In each color mode, press [CH ▲ / ▼] buttons to adjust the values of color.
- Adjust Red and Blue color so that the temperature becomes 9200K (x: 286 / y: 294) $\pm 3\%$.
- At this time, re-check that horizontal line is white. If not, re-adjust Cut-off Adjustment until the horizontal line becomes pure white.
- Turn off and on again to return to normal mode. Receive APL 100% white signal and confirm that Chroma temperatures become 9200K (x: 286 / y: 294) $\pm 3\%$.

Note: Confirm that Cut Off Adj. is correct after this adjustment, and attempt Cut Off Adj. if needed.

9. Sub-Brightness Adjustment

Purpose: To get proper brightness.

Symptom of Misadjustment: If Sub-Brightness is incorrect, proper brightness cannot be obtained by adjusting the Brightness Control.

Test Point	Adj. Point	Mode	Input
---	[CH ▲ / ▼] buttons	---	SMPTE 7.5IRE
Tape	M. EQ.	Spec.	
---	Pattern Generator	See below	

Figure

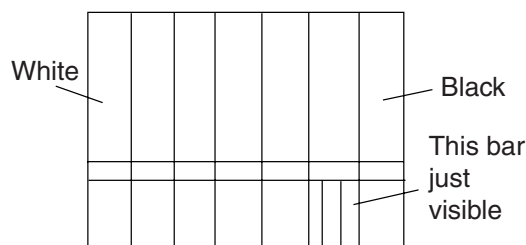

Fig. 7

Note: SMPTE Setup level --- 7.5 IRE

- Enter the Service mode. (See page 1-7-1.) Then input SMPTE signal from RF input.
- Press [PICTURE] button. (Press [PICTURE] button then display will change BRT, CNT, COL, TNT, V-TNT, and SHP). Select BRT and press [CH ▲ / ▼] buttons so that the bar is just visible (See above figure).

10. Focus Adjustment

Purpose: Set the optimum Focus.

Symptom of Misadjustment: If Focus Adjustment is incorrect, blurred images are shown on the display.

Test Point	Adj. Point	Mode	Input
---	Focus Control	---	Monoscope
Tape	M. EQ.	Spec.	
---	Pattern Generator	See below	

Note: Focus VR --- FBT (Sub CBA),
FBT = Fly Back Transformer

1. Operate the unit more than 30 minutes.
2. Face the unit to the East and degauss the CRT using a degaussing coil.
3. Input the monoscope pattern.
4. Adjust the Focus Control on the FBT to obtain a clear picture.

11. H. Position Adjustment

Purpose: To obtain correct horizontal position of screen image.

Symptom of Misadjustment: H. position may not be properly displayed.

Test Point	Adj. Point	Mode	Input
---	[CH ▲ / ▼] buttons	---	Monoscope
Tape	M. EQ.	Spec.	
---	Pattern Generator	---	

1. Enter the Service mode. (See page 1-7-1.) Press [8] button on the remote control unit and select H-P mode.
2. Input monoscope pattern.
3. Press [CH ▲ / ▼] buttons on the remote control unit so that the left and right side of the monoscope pattern are equal to each other.

12. V. Shift Adjustment

Purpose: To obtain correct vertical position of screen image.

Symptom of Misadjustment: If V. position is incorrect, vertical position of image on the screen may not be properly displayed.

Test Point	Adj. Point	Mode	Input
---	[CH ▲ / ▼] buttons	---	Monoscope
Tape	M. EQ.	Spec.	
---	Pattern Generator	---	

1. Enter the Service mode. (See page 1-7-1.) Press [9] button on the remote control unit and select V-P mode. (Press [9] button then display will change to V-P and V-S).
2. Input monoscope pattern.
3. Press [CH ▲ / ▼] buttons on the remote control unit so that the top and bottom of the monoscope pattern are equal to each other.

13. V. Size Adjustment

Purpose: To obtain correct vertical height of screen image.

Symptom of Misadjustment: If V. Size is incorrect, vertical height of image on the screen may not be properly displayed.

Test Point	Adj. Point	Mode	Input
---	[CH ▲ / ▼] buttons	---	Monoscope
Tape	M. EQ.	Spec.	
---	Pattern Generator	90±5%	

1. Enter the Service mode. (See page 1-7-1.) Press [9] button on the remote control unit and select V-S mode. (Press [9] button then display will change to V-P and V-S).
2. Input monoscope pattern.
3. Press [CH ▲ / ▼] buttons on the remote control unit so that the monoscope pattern is 90±5% of display size and the circle is round.

14. Head Switching Position Adjustment

Purpose: Determine the Head Switching Position during Playback.

Symptom of Misadjustment: May cause Head Switching Noise or Vertical Jitter in the picture.

Note: Unit reads Head Switching Position automatically and displays it on the screen (Upper Left Corner).

1. Playback test tape (FL8A, FL8N).
2. Enter the Service mode. (See page 1-7-1.) Then press the number [5] button on the remote control unit.
3. The Head Switching position will display on the screen; if adjustment is necessary follow step 4. 6.5H(412.7 μ s) is preferable.
4. Press [CH ▲] or [CH ▼] button on the remote control unit if necessary. The value will be changed in 0.5H steps up or down. Adjustable range is up to 9.5H. If the value is beyond adjustable range, the display will change as:
Lower out of range: 0.0H
Upper out of range: -.H

The following 2 adjustments normally are not attempted in the field. They should be done only when replacing the CRT then adjust as a preparation.

15. Purity Adjustment

Purpose: To obtain pure color.

Symptom of Misadjustment: If Color Purity Adjustment is incorrect, large areas of color may not be properly displayed.

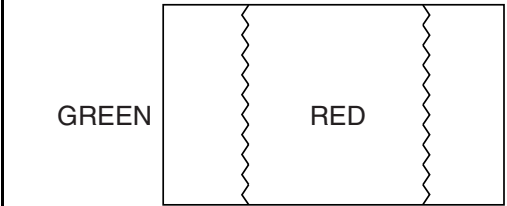
Test Point	Adj. Point	Mode	Input
---	Deflection Yoke Purity Magnet	---	*Red Color
Tape	M. EQ.	Spec.	
---	Pattern Generator	See below	
Figure			
			
			Fig. 8

* This becomes RED COLOR if the [7] button is pressed while in service mode.

1. Set the unit facing east.
2. Operate the unit for over 30 minutes before adjusting.
3. Fully degauss the unit using an external degaussing coil.
4. Set the unit to the AUX mode which is located before CH2 then input a red raster from video in.
5. Loosen the screw on the Deflection Yoke Clamper and pull the Deflection Yoke back away from the screen. (See Fig. 9.)
6. Loosen the Ring Lock and adjust the Purity Magnets so that a red field is obtained at the center of the screen. Tighten Ring Lock. (See Fig. 8, 9.)
7. Slowly push the Deflection Yoke toward the bell of the CRT and set it where a uniform red field is obtained.
8. Tighten the clamp screw on the Deflection Yoke.

16. Convergence Adjustment

Purpose: To obtain proper convergence of red, green and blue beams.

Symptom of Misadjustment: If Convergence Adjustment is incorrect, the edge of white letters may have color edges.

4. Fix the C.P. Magnets by tightening the Ring Lock.
5. Remove the DY Wedges and slightly tilt the Deflection Yoke horizontally and vertically to obtain the best overall convergence.
6. Fix the Deflection Yoke by carefully inserting the DY Wedges between CRT and Deflection Yoke.

Test Point	Adj. Point	Mode	Input
---	C.P. Magnet (RB) C.P. Magnet (RB-G) Deflection Yoke	---	Dot Pattern or Crosshatch
Tape	M. EQ.	Spec.	
---	Pattern Generator	See below	

Figure

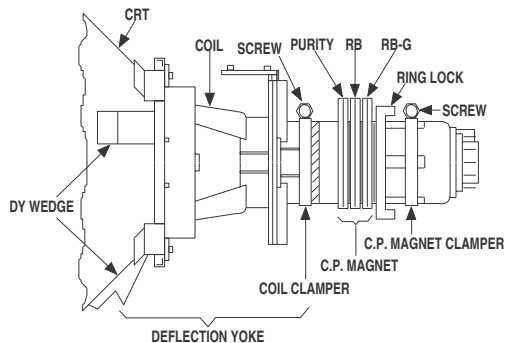

Fig. 9

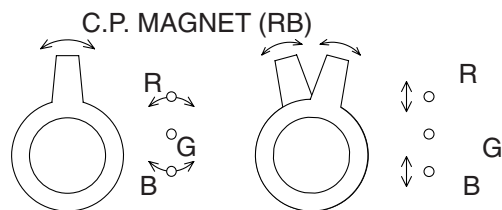

Fig. 10

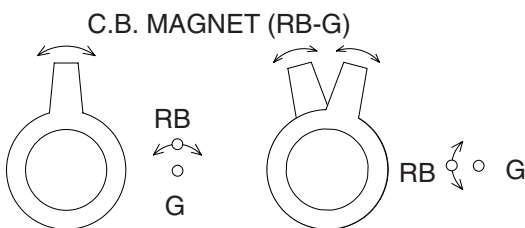

Fig. 11

1. Set the unit to the AUX mode which is located before CH2 then input a dot or crosshatch pattern.
2. Loosen the Ring Lock and align red with blue dots or crosshatch at the center of the screen by rotating (RB) C.P. Magnets. (See Fig. 10.)
3. Align red / blue with green dots at the center of the screen by rotating (RB-G) C.P. Magnet. (See Fig. 11.)

HOW TO INITIALIZE THE TV/DVD/VCR

To put the program back at the factory-default, initialize the TV/DVD/VCR as the following procedure.

< DVD Section >

1. Turn the power on and press [SELECT] button on the remote control unit to put the TV/DVD/VCR into DVD mode.
2. Press [1], [2], [3], [4], and [DISPLAY] buttons on the remote control unit in that order. Fig. a appears on the screen.

"*****" differ depending on the models.

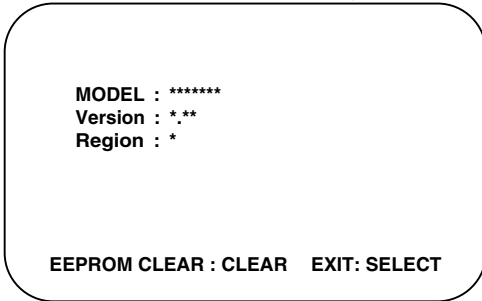

Fig. a

3. Press [CLEAR] button on the remote control unit. Fig. b appears on the screen.

"*****" differ depending on the models.

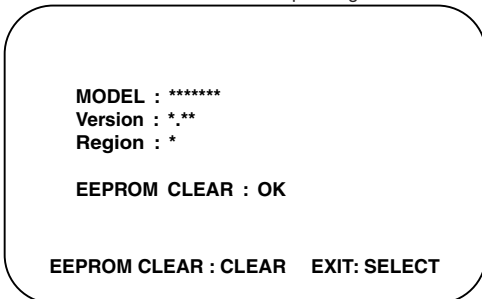

Fig. b

When "OK" appears on the screen, the factory default will be set. Then the firmware renewal mode is complete.

4. To exit this mode, press [CH ▲ / ▼] or [SELECT] button to go to TV mode, or press [POWER] button to turn the power off.

< TV/VCR Section >

1. Use the service remote control unit.
2. Turn the power on. (Use main power on the TV unit.)
3. Press [DISC MENU] button on the service remote control unit to enter the Service mode. (Refer to "How to Set up the Service mode" on page 1-7-1.)
4. Press [VOL ▼] button on the service remote control unit twice, and confirm that OSD indication is "7F = FF." If needed, set it to become "7F = FF" by pressing [CH ▲ / ▼] buttons on the service remote control unit.
5. Confirm that OSD indication on the four corners on TV screen changes from on and off light indication to red by pressing a [DISPLAY] button. (It takes one or two seconds.)
6. Turn the power off by pressing main power button on the TV unit, and unplug the AC cord from the AC outlet.

FIRMWARE RENEWAL MODE

1. Turn the power on and press [SELECT] button on the remote control unit to put the TV/DVD/VCR into DVD mode. Then remove the disc on the tray. (It is possible to move to F/W version up mode only when the TV/DVD/VCR is in DVD mode with the tray opened.)
2. To put the TV/DVD/VCR into F/W version up mode, press [9], [8], [7], [6], and [SEARCH MODE] buttons on the remote control unit in that order. Fig. a appears on the screen.

"*****" differ depending on the models.

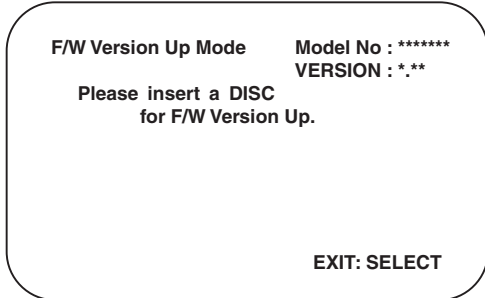

Fig. a Version Up Mode Screen

The TV/DVD/VCR can also enter the version up mode with the tray open. In this case, Fig. a will be shown on the screen while the tray is open.

3. Load the disc for version up.
4. The TV/DVD/VCR enters the F/W version up mode automatically. Fig. b appears on the screen. If you enter the F/W for different models, "Disc Error" will appear on the screen, then the tray will open automatically.

"*****" differ depending on the models.

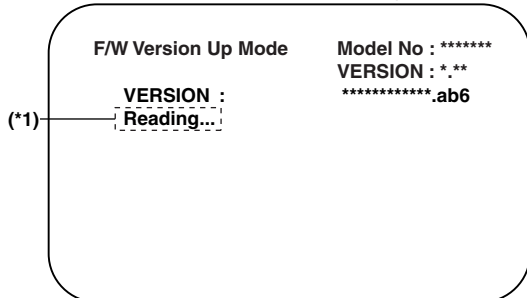

Fig. b Programming Mode Screen

The appearance shown in (*1) of Fig. b is described as follows:

No.	Appearance	State
1	Reading...	Sending files into the memory
2	Erasing...	Erasing previous version data
3	Programming...	Writing new version data

5. After programming is finished, the tray opens automatically. Fig. c appears on the screen and the checksum will be shown in (*2) of Fig. c.

"*****" differ depending on the models.

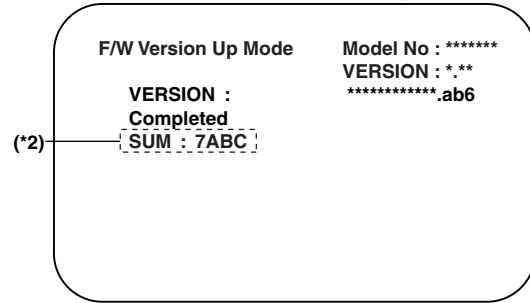

Fig. c Completed Program Mode Screen

At this time, no button is available.

6. Remove the disc on the tray.
7. Press [SELECT] button on the remote control unit to go to TV mode, or press [POWER] button on the unit to turn the power off.
8. Press [SELECT] button on the remote control unit to put the TV/DVD/VCR into DVD mode again.
9. Press [1], [2], [3], [4], and [DISPLAY] buttons on the remote control unit in that order. Fig. d appears on the screen.

"*****" differ depending on the models.

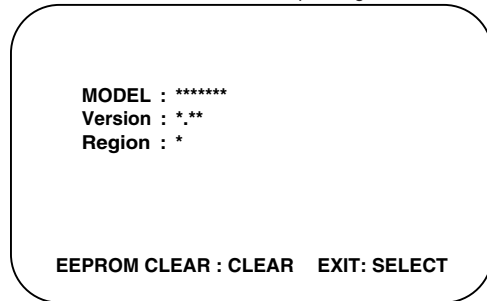

Fig. d

10. Press [CLEAR] button on the remote control unit. Fig. e appears on the screen.

"*****" differ depending on the models.

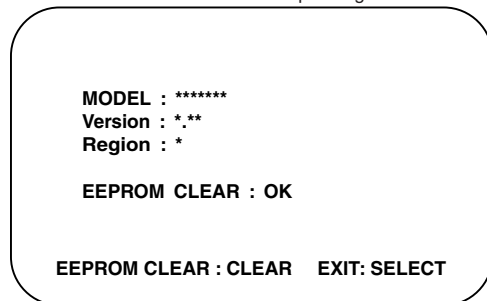

Fig. e

When "OK" appears on the screen, the factory default will be set. Then the firmware renewal mode is complete.

11. To exit this mode, press [CH ▲ / ▼] or [SELECT] button to go to TV mode, or press [POWER] button to turn the power off.

BLOCK DIAGRAMS < TV/VCR Section >

System Control / Servo Block Diagram

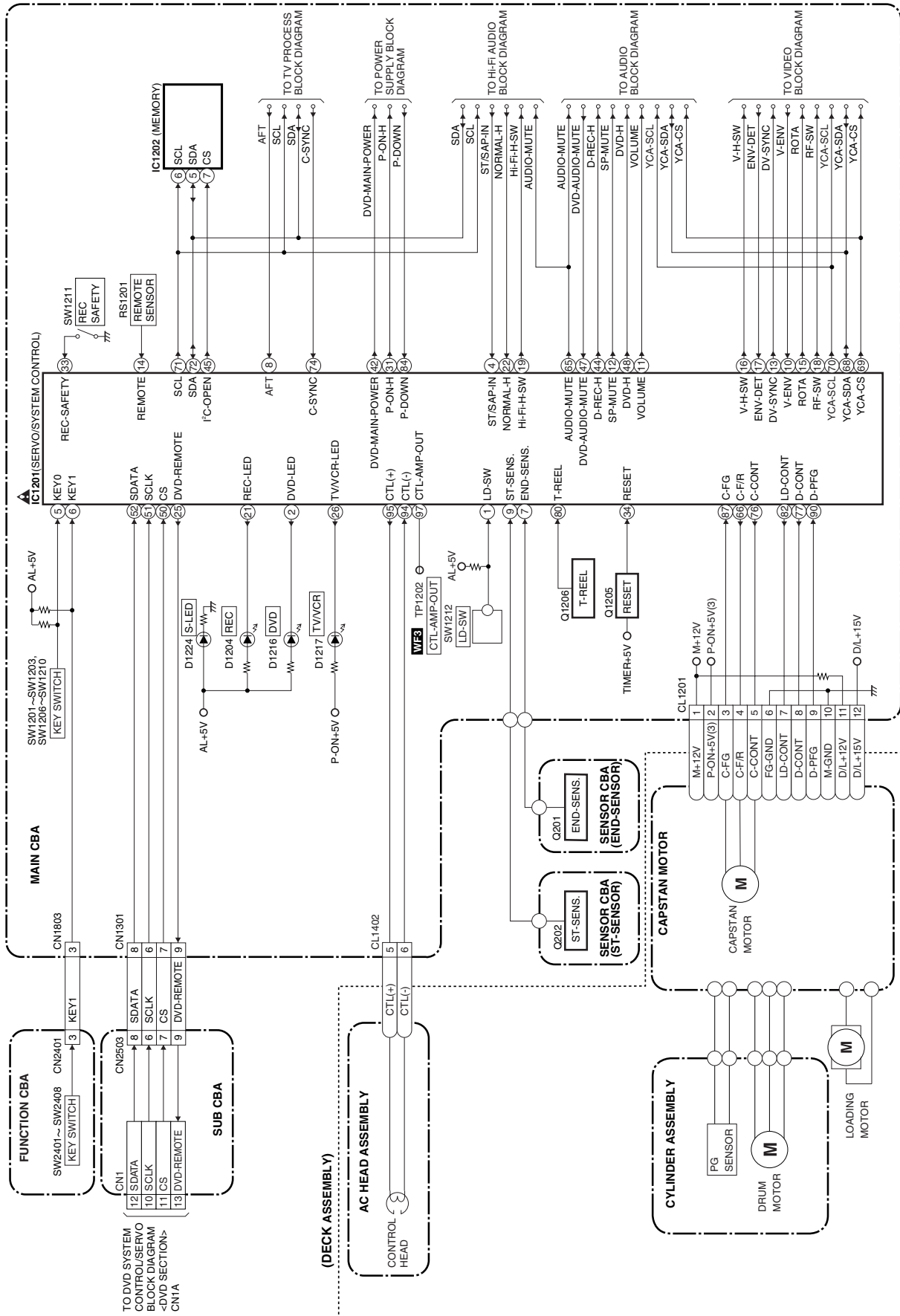

Video Block Diagram

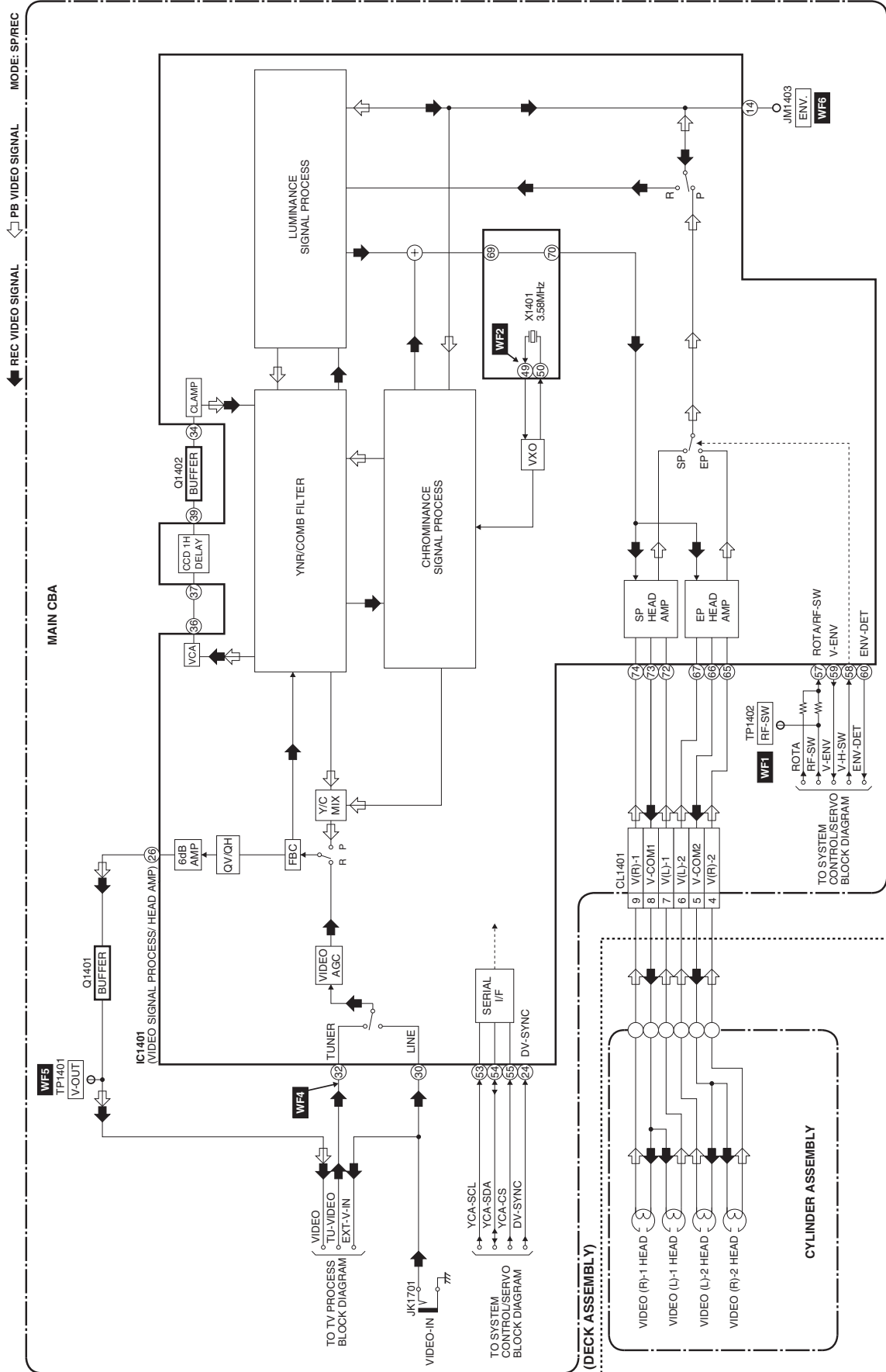

Audio Block Diagram

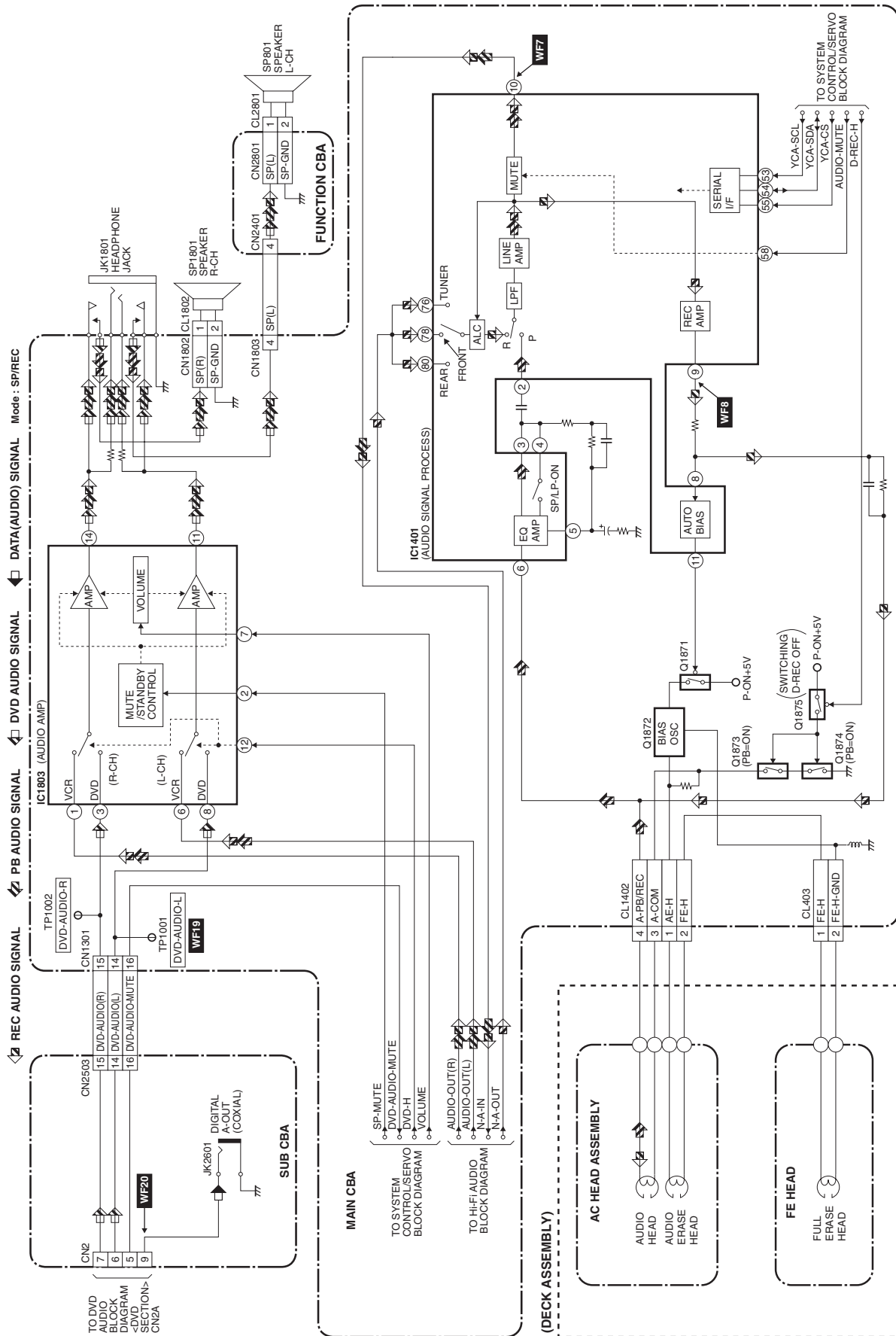

TV Process Block Diagram

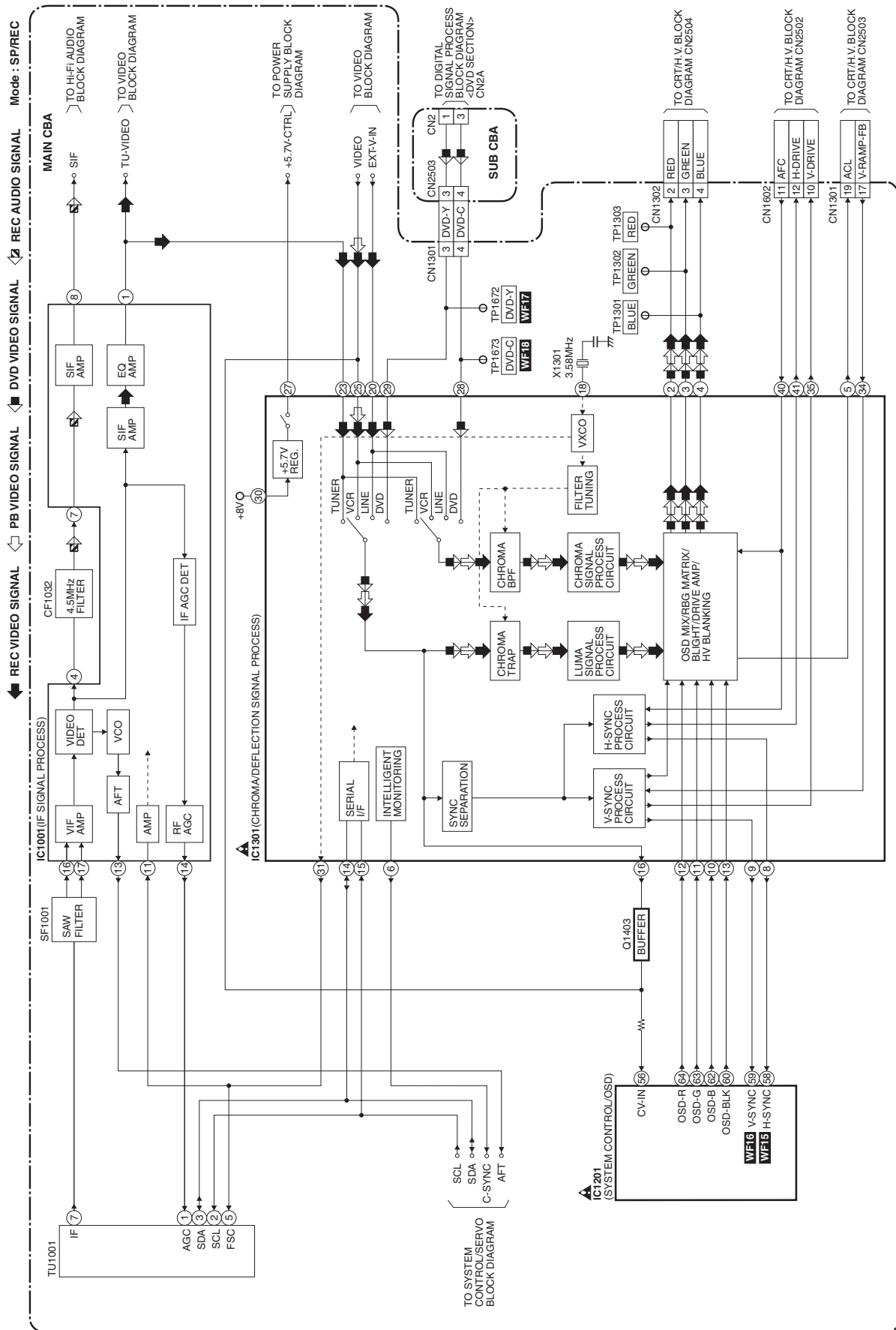

CRT/H.V. Block Diagram

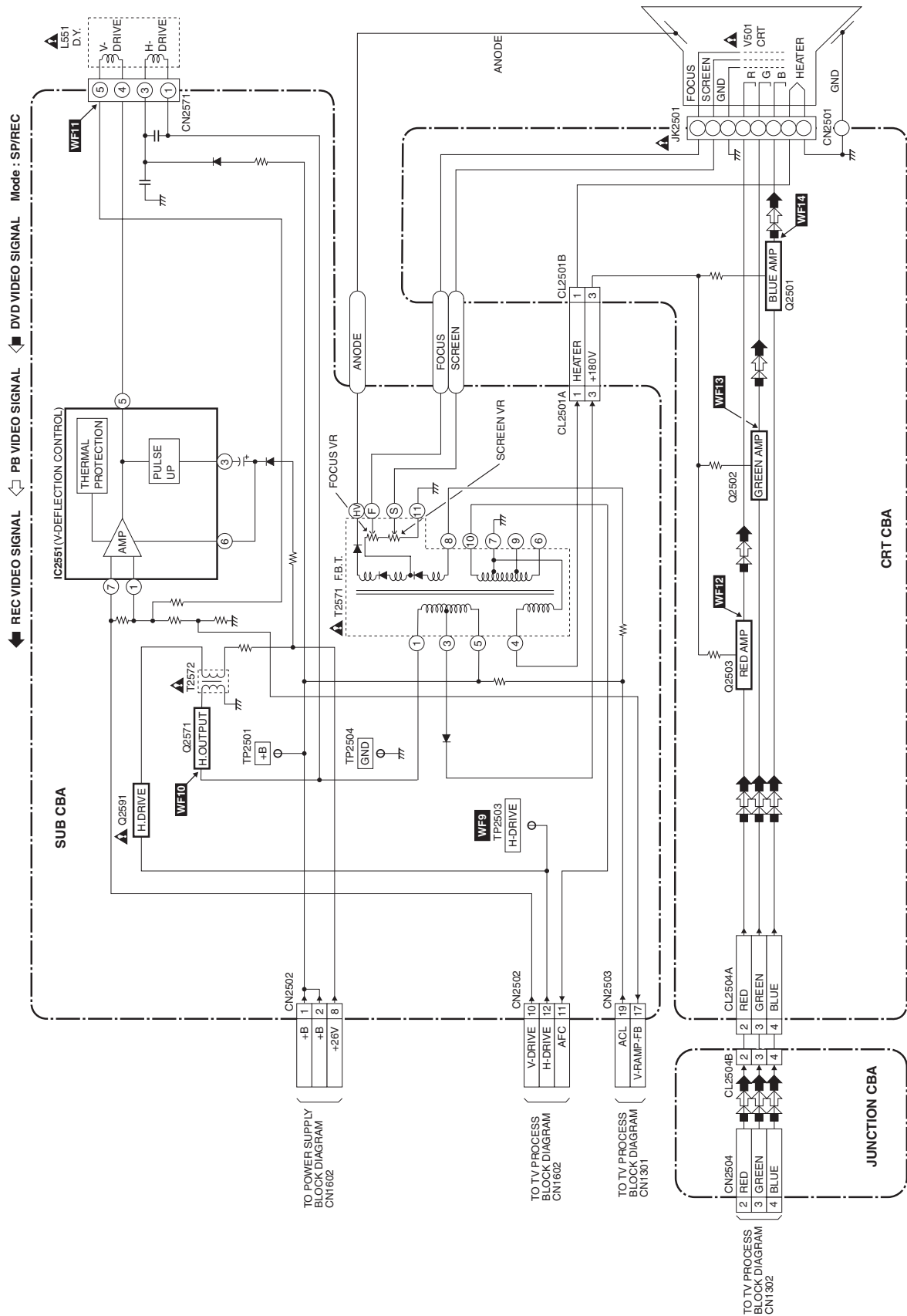

BLOCK DIAGRAMS < DVD Section >

DVD System Control / Servo Block Diagram

*1 NOTE:
Either IC461 or IC462 is used for DVD MAIN CBA UNIT.

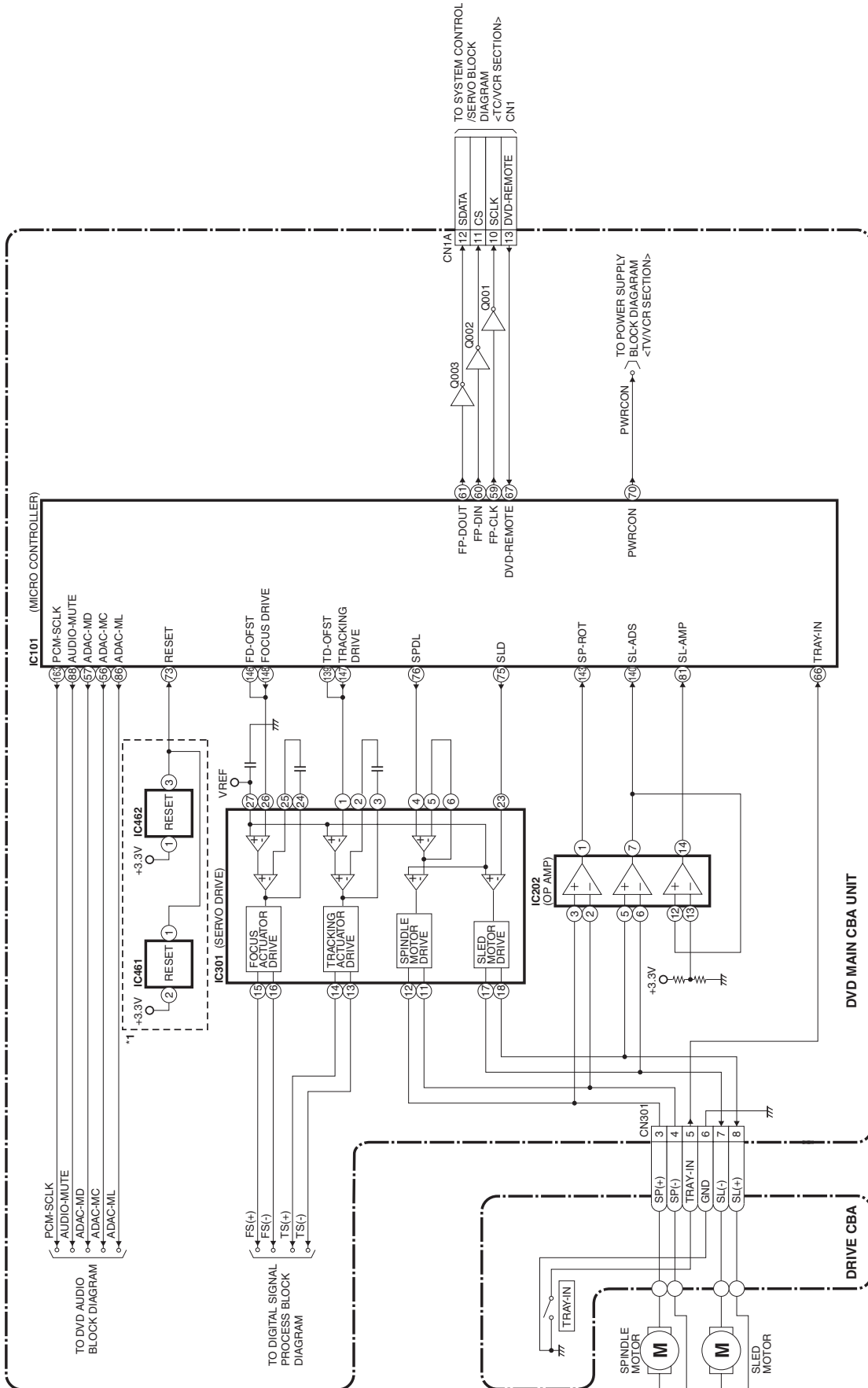

Digital Signal Process Block Diagram

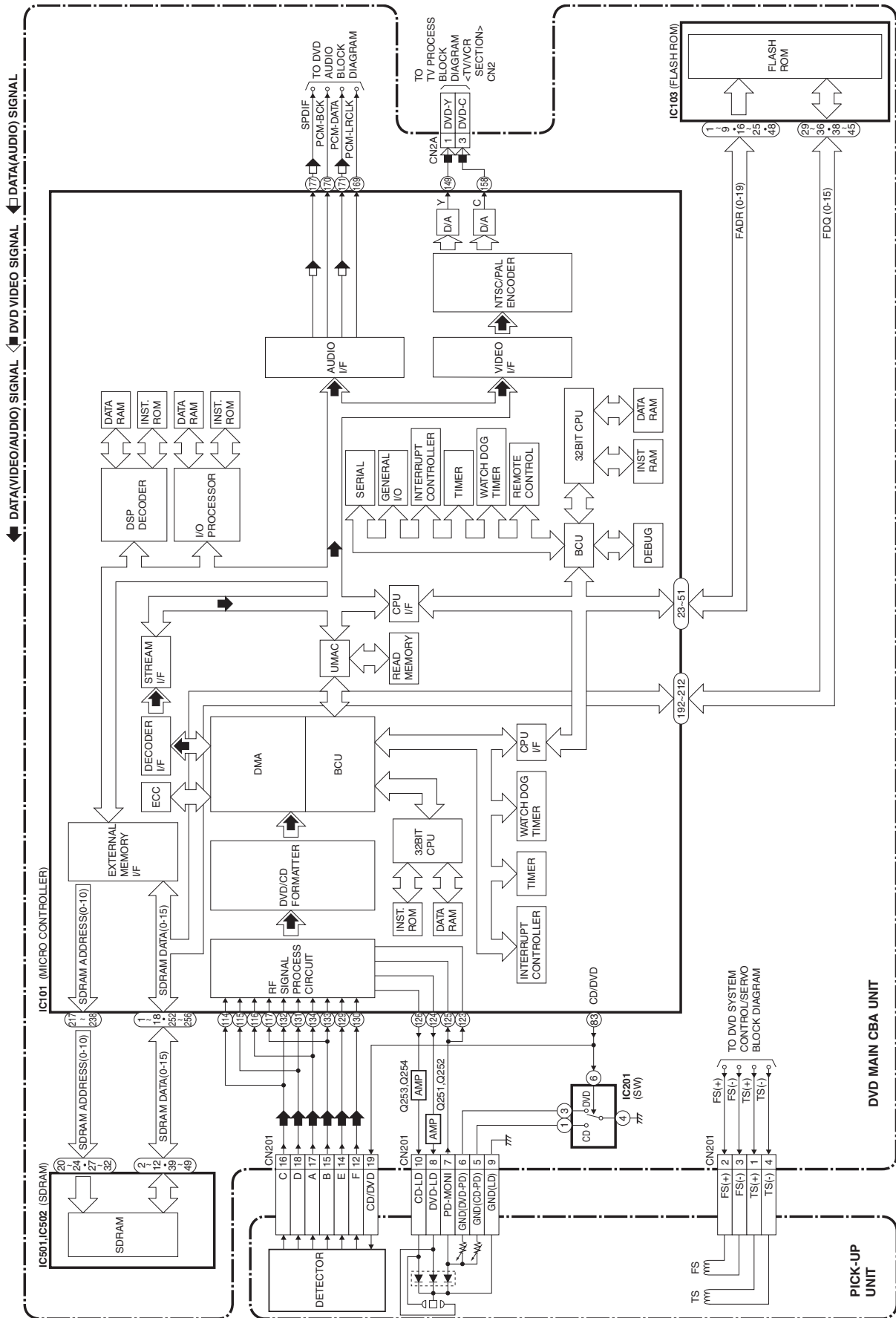

DVD Audio Block Diagram

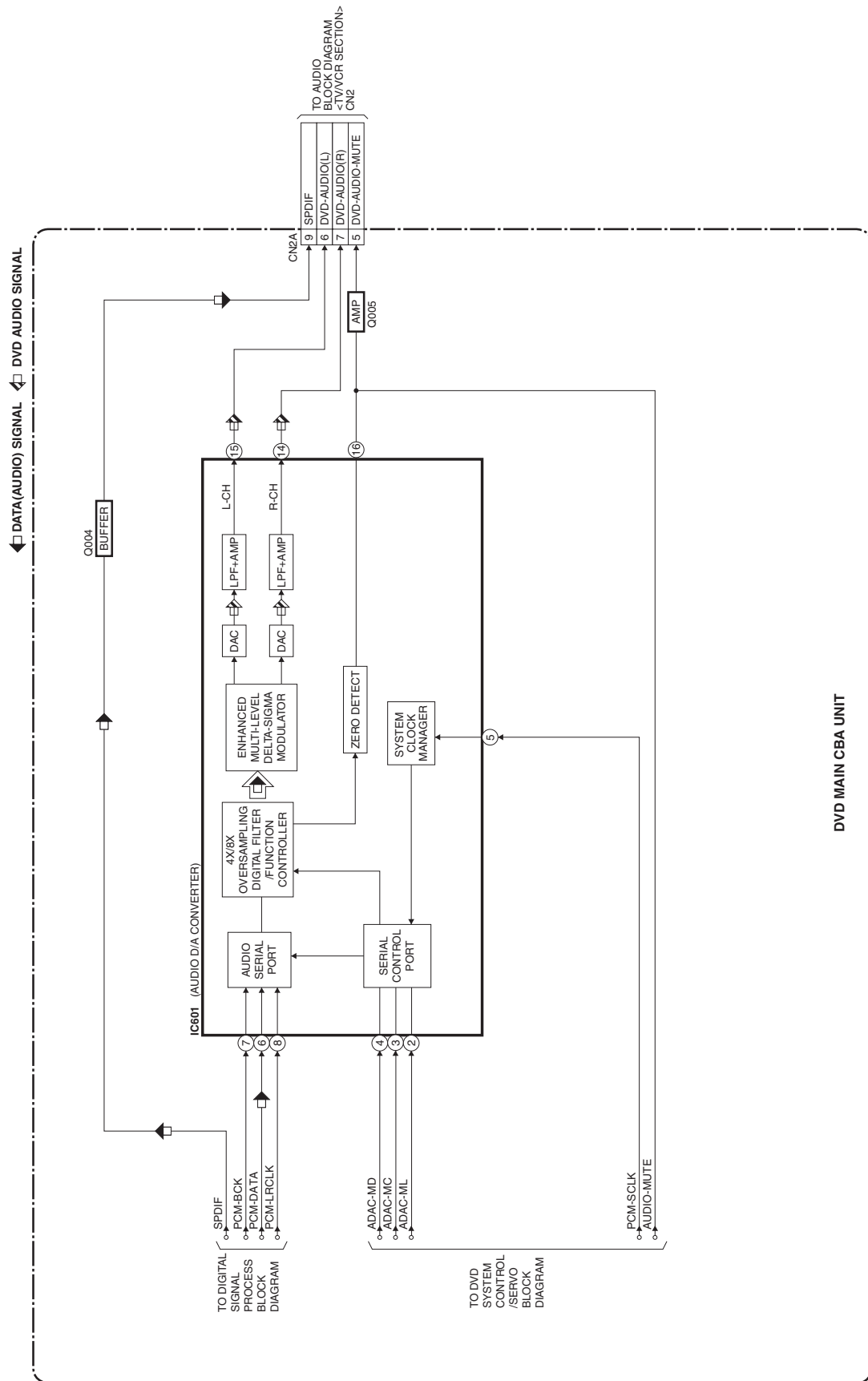

SCHEMATIC DIAGRAMS / CBA'S AND TEST POINTS

Standard Notes

WARNING

Many electrical and mechanical parts in this chassis have special characteristics. These characteristics often pass unnoticed and the protection afforded by them cannot necessarily be obtained by using replacement components rated for higher voltage, wattage, etc. Replacement parts that have these special safety characteristics are identified in this manual and its supplements; electrical components having such features are identified by the mark "▲" in the schematic diagram and the parts list. Before replacing any of these components, read the parts list in this manual carefully. The use of substitute replacement parts that do not have the same safety characteristics as specified in the parts list may create shock, fire, or other hazards.

Notes:

1. Do not use the part number shown on these drawings for ordering. The correct part number is shown in the parts list, and may be slightly different or amended since these drawings were prepared.
2. All resistance values are indicated in ohms (K = 10^3 , M = 10^6).
3. Resistor wattages are 1/4W or 1/6W unless otherwise specified.
4. All capacitance values are indicated in μF (P = 10^{-6} μF).
5. All voltages are DC voltages unless otherwise specified.

LIST OF CAUTION, NOTES, AND SYMBOLS USED IN THE SCHEMATIC DIAGRAMS ON THE FOLLOWING PAGES:

1. CAUTION: FOR CONTINUED PROTECTION AGAINST RISK OF FIRE, REPLACE ONLY WITH SAME TYPE_A,_V FUSE.

ATTENTION: UTILISER UN FUSIBLE DE RECHANGE DE MÊME TYPE DE_A,_V.

2. CAUTION:

Fixed Voltage (or Auto voltage selectable) power supply circuit is used in this unit.

If Main Fuse (F1601) is blown, first check to see that all components in the power supply circuit are not defective before you connect the AC plug to the AC power supply. Otherwise it may cause some components in the power supply circuit to fail.

3. Note:

- Do not use the part number shown on the drawings for ordering. The correct part number is shown in the parts list, and may be slightly different or amended since the drawings were prepared.
- To maintain original function and reliability of repaired units, use only original replacement parts which are listed with their part numbers in the parts list section of the service manual.

4. Mode: SP/REC

5. Voltage indications for PLAY and REC modes on the schematics are as shown below:

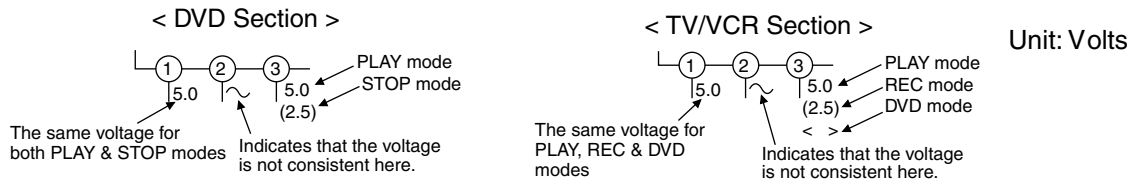

6. How to read converged lines

1-D3
 ↑ Distinction Area
 ↑ Line Number
 (1 to 3 digits)

Examples:

- "1-D3" means that line number "1" goes to the line number "1" of the area "D3".
- "1-B1" means that line number "1" goes to the line number "1" of the area "B1".

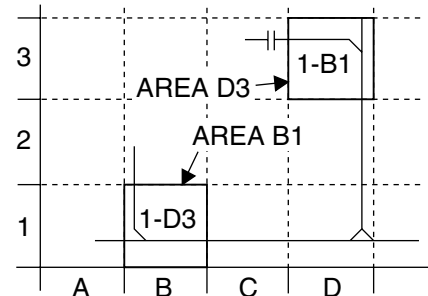

7. Test Point Information

⊕ : Indicates a test point with a jumper wire across a hole in the PCB.

□→ : Used to indicate a test point with a component lead on foil side.

⊘ : Used to indicate a test point with no test pin.

● : Used to indicate a test point with a test pin.

Main 1/6 Schematic Diagram < TV/VCR Section >

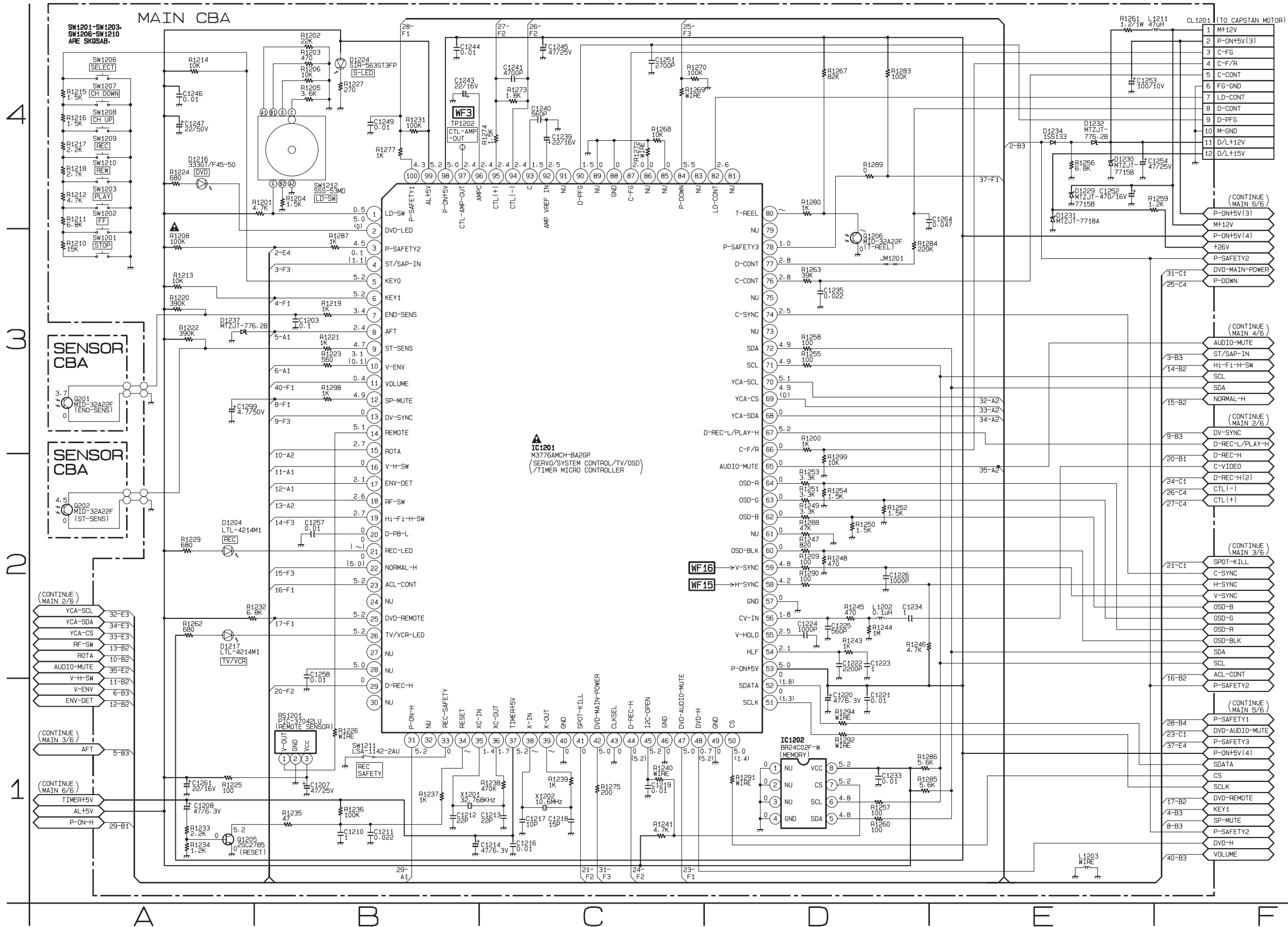

MAIN 1/6

Ref No.	Position
ICS	
IC1201	C-3
IC1202	D-1
TRANSISTORS	
Q1205	A-1
Q1206	D-3
CONNECTOR	
CL1201	F-4
TEST POINT	
TP1202	B-4

Main 2/6 Schematic Diagram < TV/VCR Section >

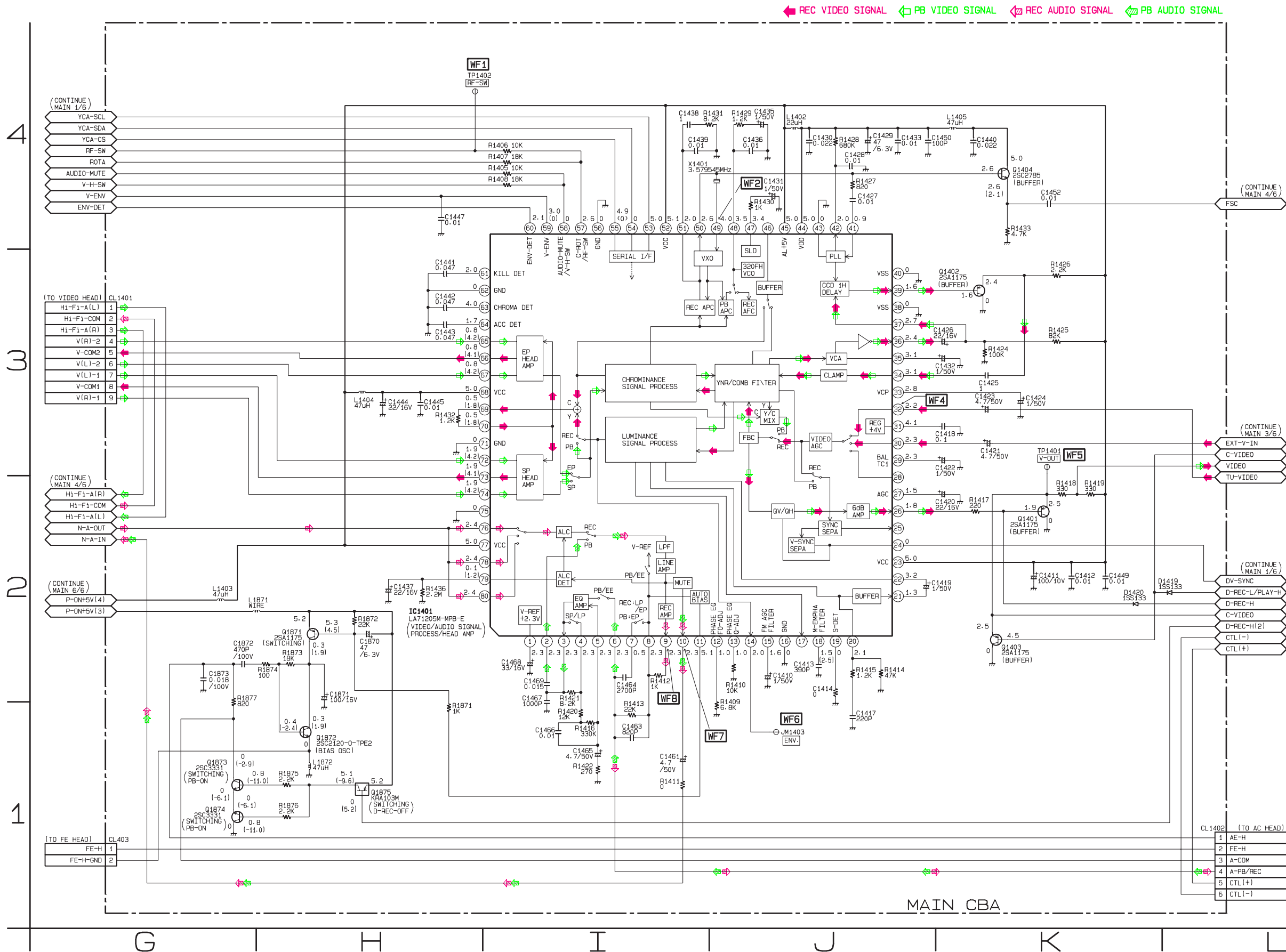

MAIN 2/6	
Ref No.	Position
IC	
IC1401	H-2
TRANSISTORS	
Q1401	K-2
Q1402	K-3
Q1403	K-2
Q1404	K-4
Q1871	H-2
Q1872	H-1
Q1873	G-1
Q1874	G-1
Q1875	H-1
CONNECTORS	
CL403	G-1
CL1401	G-3
CL1402	L-1
TEST POINTS	
JM1403	J-1
TP1401	K-3
TP1402	H-4

Main 3/6 Schematic Diagram < TV/VCR Section >

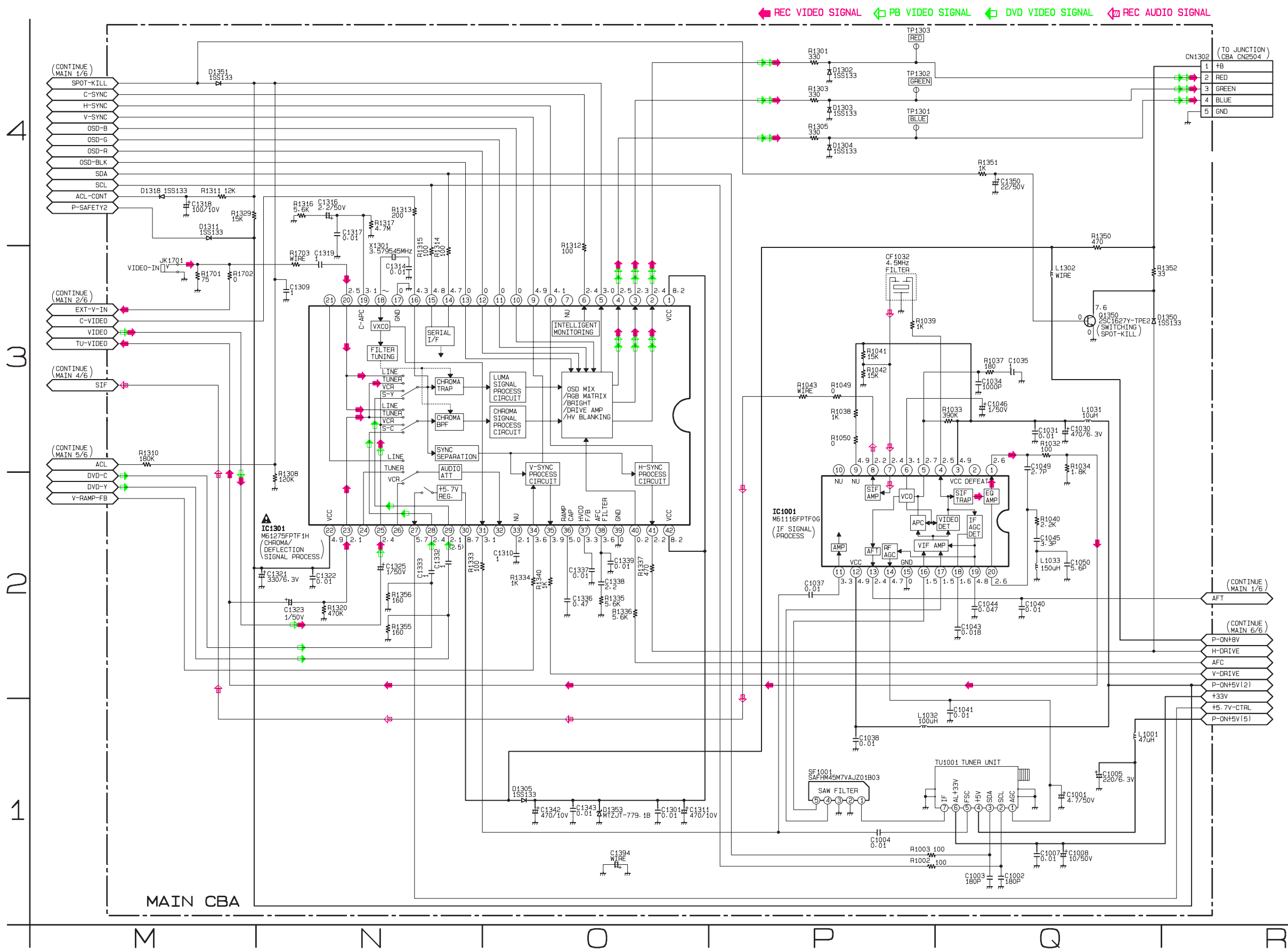

MAIN 3/6

Ref No.	Position
ICS	
IC1001	P-2
IC1301	N-2
TRANSISTOR	
Q1350	Q-3
CONNECTOR	
CN1302	R-4
TEST POINTS	
TP1301	P-4
TP1302	P-4
TP1303	P-4

Main 5/6 Schematic Diagram < TV/VCR Section >

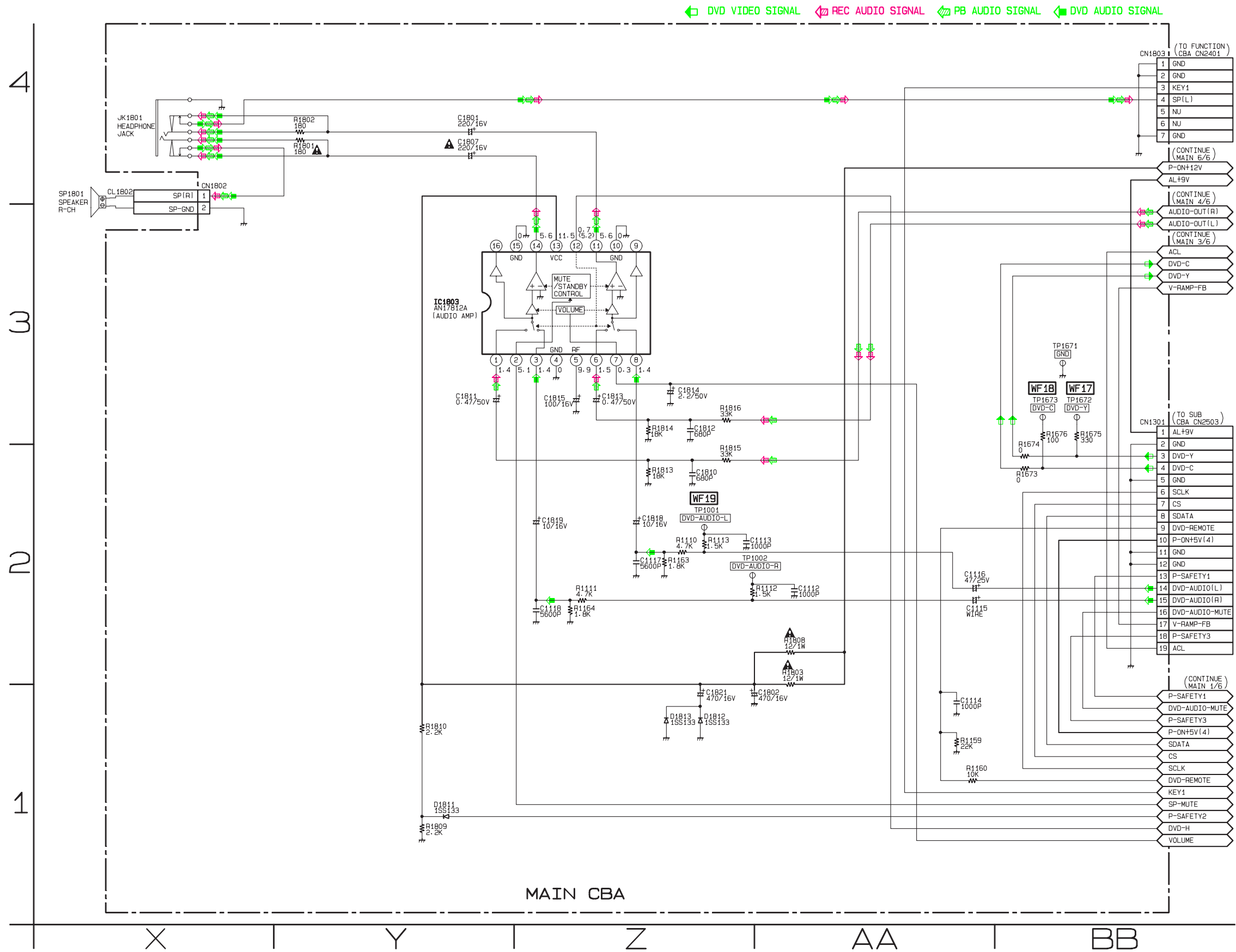

MAIN 5/6

Ref No.	Position
IC	
IC1803	Y-3
CONNECTORS	
CN1301	BB-3
CN1802	X-4
CN1803	BB-4
TEST POINTS	
TP1001	Z-2
TP1002	Z-2
TP1671	BB-3
TP1672	BB-3
TP1673	BB-3

Main 6/6 Schematic Diagram < TV/VCR Section >

CAUTION !

Fixed voltage (or Auto voltage selectable) power supply circuit is used in this unit.
If Main Fuse (F1601) is blown, check to see that all components in the power supply circuit are not defective before you connect the AC plug to the AC power supply.
Otherwise it may cause some components in the power supply circuit to fail.

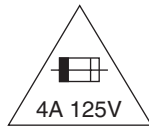

CAUTION ! : For continued protection against risk of fire, replace only with same type 4 A, 125V fuse.

ATTENTION : Utiliser un fusible de rechange de même type de 4A, 125V.

NOTE:

The voltage for parts in hot circuit is measured using hot GND as a common terminal.

VOLTAGE CHART (Power off mode)

Ref. No.	1	2	3	4
IC1601	12.0	10.9	0.3	1.6
Ref. No.	1	2	3	
IC1682	3.1	0	1.9	
Ref. No.	S	D	G	
Q1601	0	164.2	1.8	
Ref. No.	E	C	B	
Q1221	5.3	5.3	3.5	
Q1602	0	1.8	0.3	
Q1604	6.8	10.9	7.4	
Q1605	0	8.0	0	
Q1606	9.2	9.2	8.6	
Q1607	0	0.1	0.7	
Q1609	5.9	8.2	6.5	
Q1613	0.8	8.1	1.4	
Q1614	0.9	8.1	1.4	
Q1681	0.4	3.2	0.9	
Q1682	0.3	3.2	0.9	
Q1683	0.8	3.2	0.9	
Q1688	0.3	3.2	0.9	

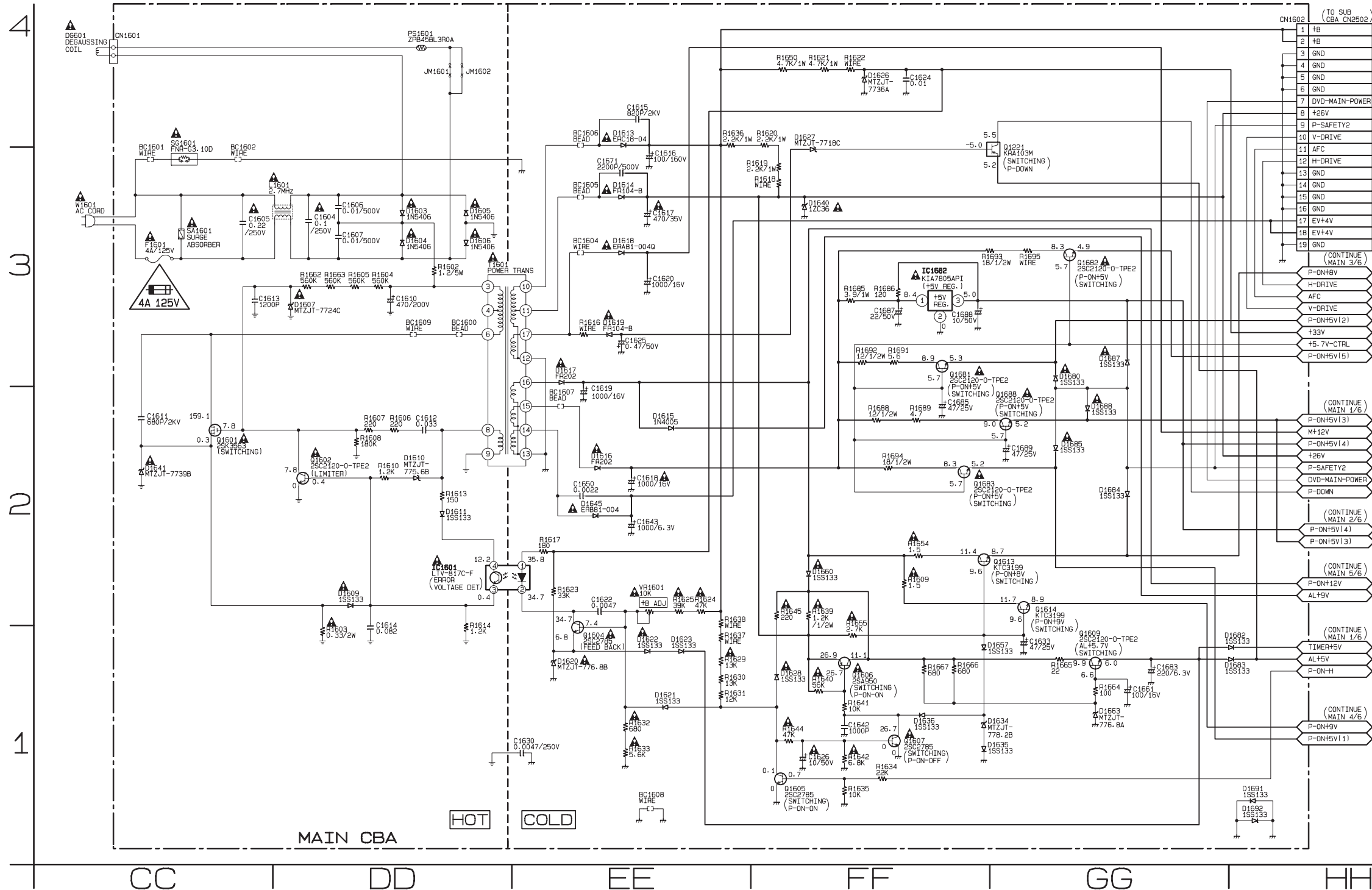

MAIN 6/6

Ref No.	Position
ICS	
IC1601	DD-2
IC1682	FF-3
TRANSISTORS	
Q1221	GG-3
Q1601	CC-2
Q1602	DD-2
Q1604	EE-1
Q1605	FF-1
Q1606	FF-1
Q1607	FF-1
Q1609	GG-1
Q1613	GG-2
Q1614	GG-2
Q1681	FF-3
Q1682	GG-3
Q1683	FF-2
Q1688	GG-2
CONNECTORS	
CN1601	CC-4
CN1602	HH-4
VARIABLE RESISTOR	
VR1601	EE-2

Sub 1/2 Schematic Diagram < TV/VCR Section >

SUB 1/2

Ref No.	Position
IC	
IC2551	A-4
TRANSISTORS	
Q2571	D-1
Q2591	B-1
Q2592	B-2
CONNECTORS	
CL2501A	E-2
CN2571	B-4
TEST POINTS	
TP2501	B-1
TP2502	B-1
TP2503	B-2
TP2504	B-1
TP2505	B-1

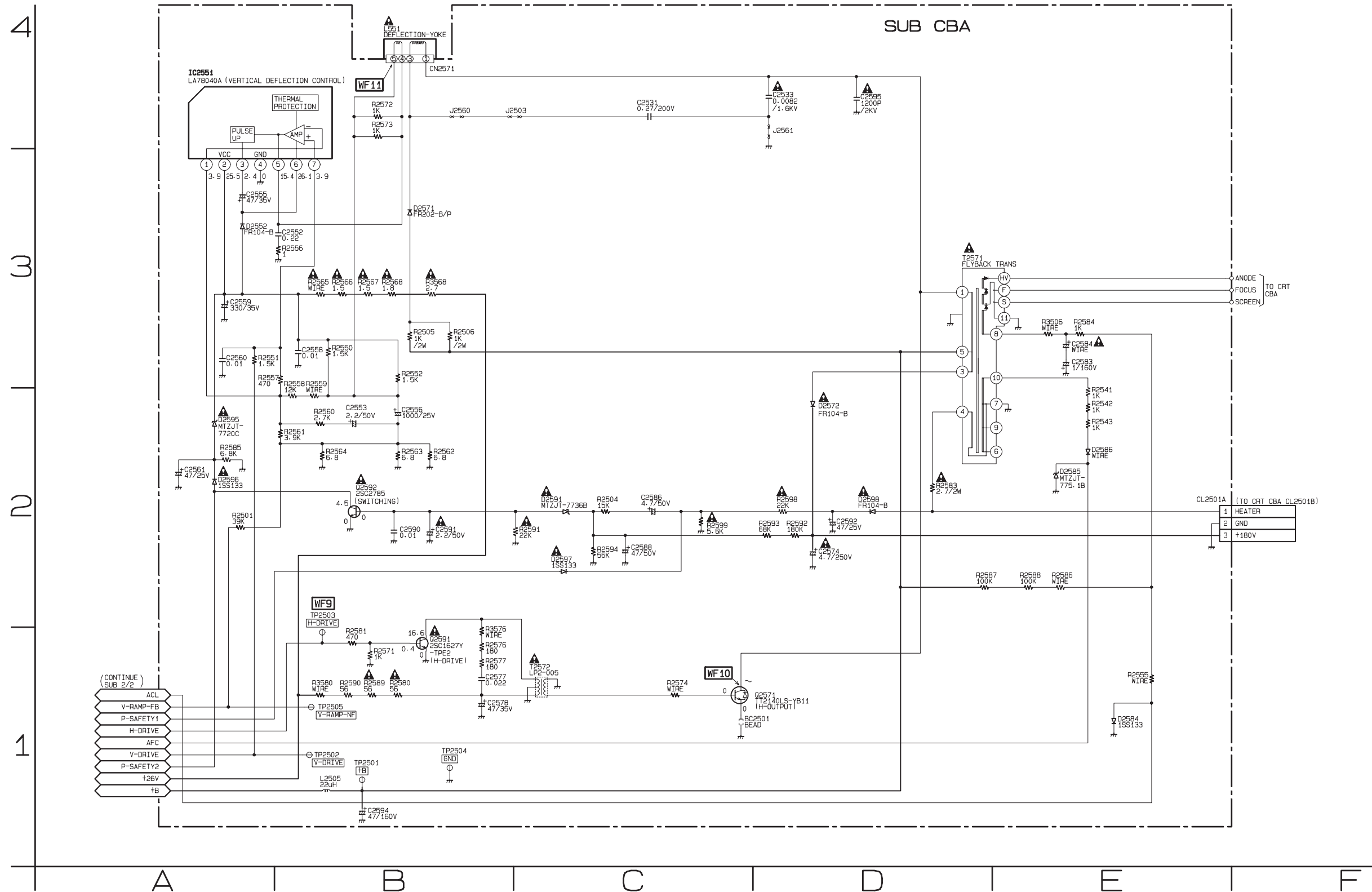

Sub 2/2 Schematic Diagram < TV/VCR Section >

SUB 2/2

Ref No.	Position
ICS	
IC2602	H-1
IC3603	H-1
IC3604	I-2
TRANSISTORS	
Q2610	H-3
Q2611	I-2
Q2612	H-2
Q2615	H-2
Q2616	H-1
Q2617	H-2
CONNECTORS	
CN1	L-2
CN2	L-3
CN2502	G-2
CN2503	G-4

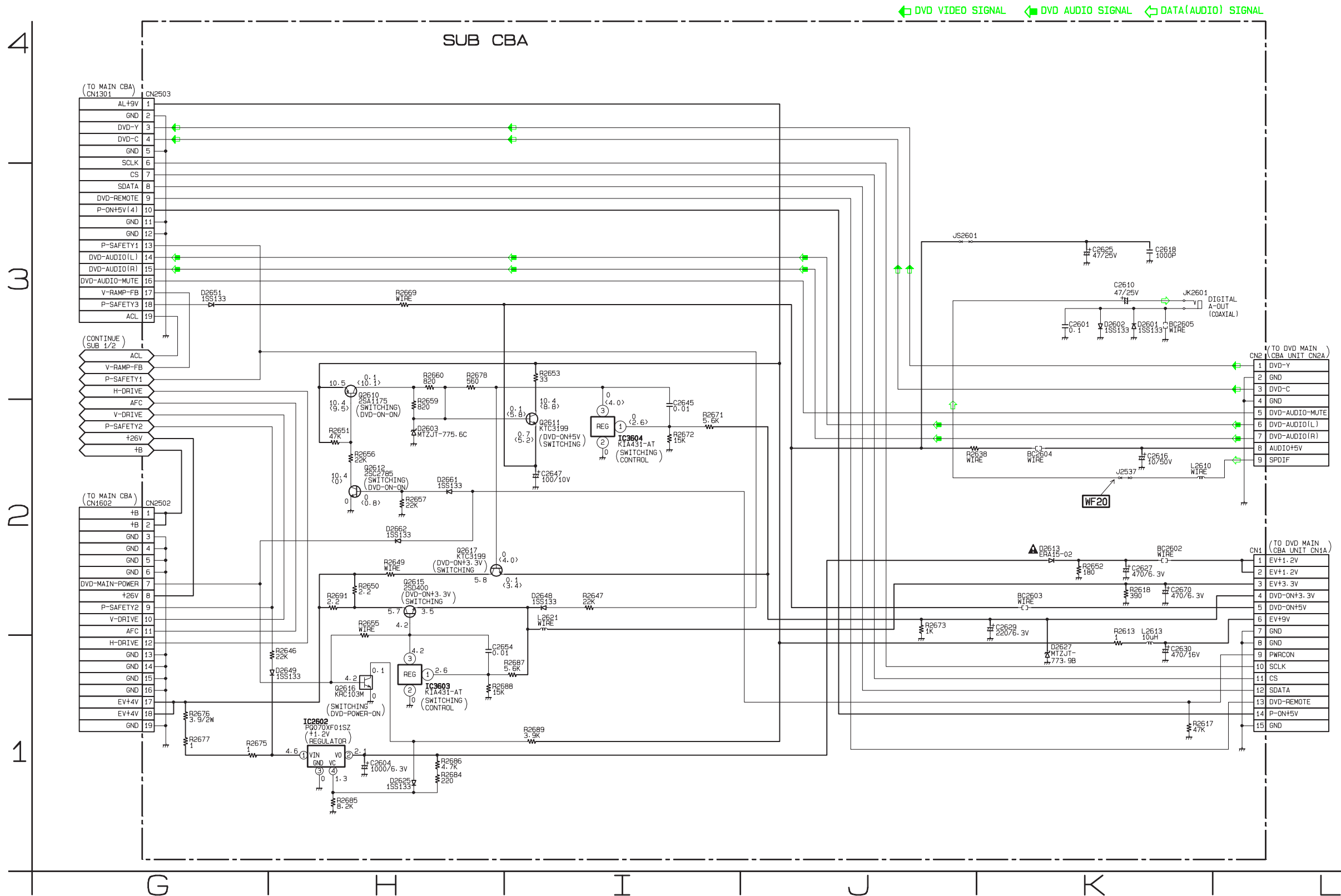

CRT Schematic Diagram < TV/VCR Section >

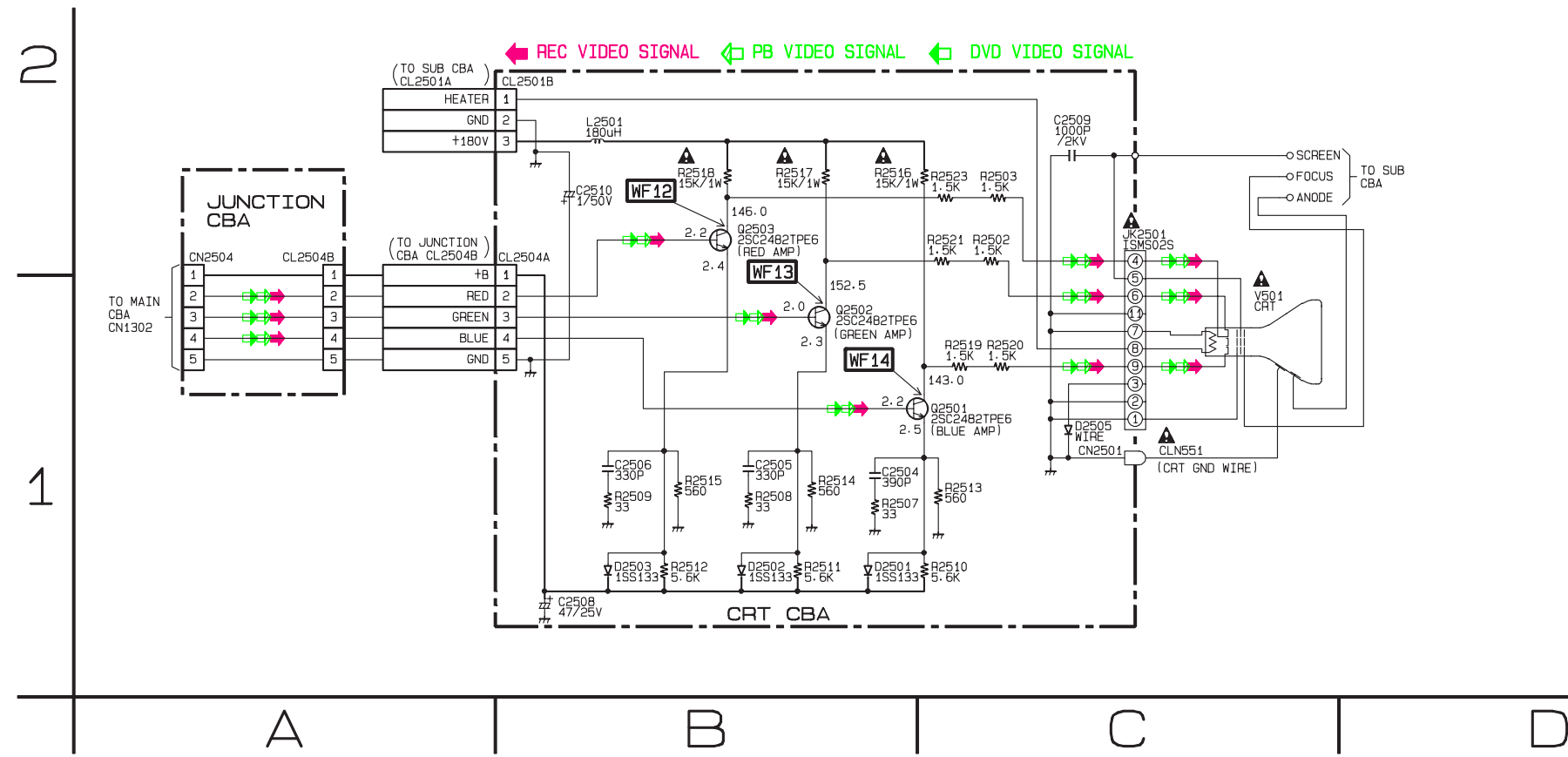

CRT	
Ref No.	Position
TRANSISTORS	
Q2501	C-1
Q2502	B-1
Q2503	B-2
CONNECTORS	
CL2501B	B-2
CL2504A	B-2
CN2501	C-1

Function Schematic Diagram < TV/VCR Section >

T1100SCCRT

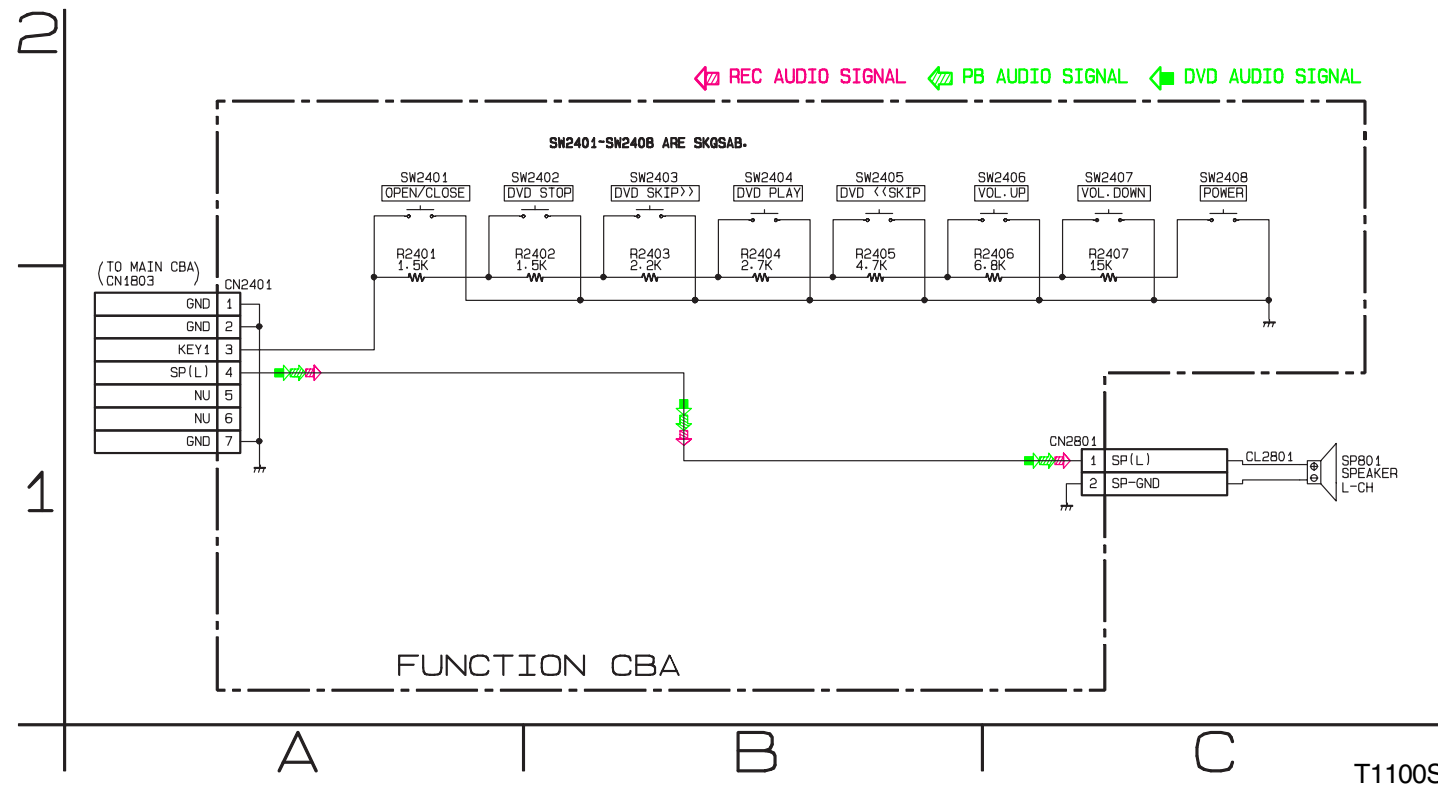

T1100SCF
1-11-11

DVD Main 1/3 Schematic Diagram < DVD Section >

***1 NOTE:**
Either IC461 or IC462 is used for DVD MAIN CBA UNIT.

← DATA (VIDEO+AUDIO) SIGNAL

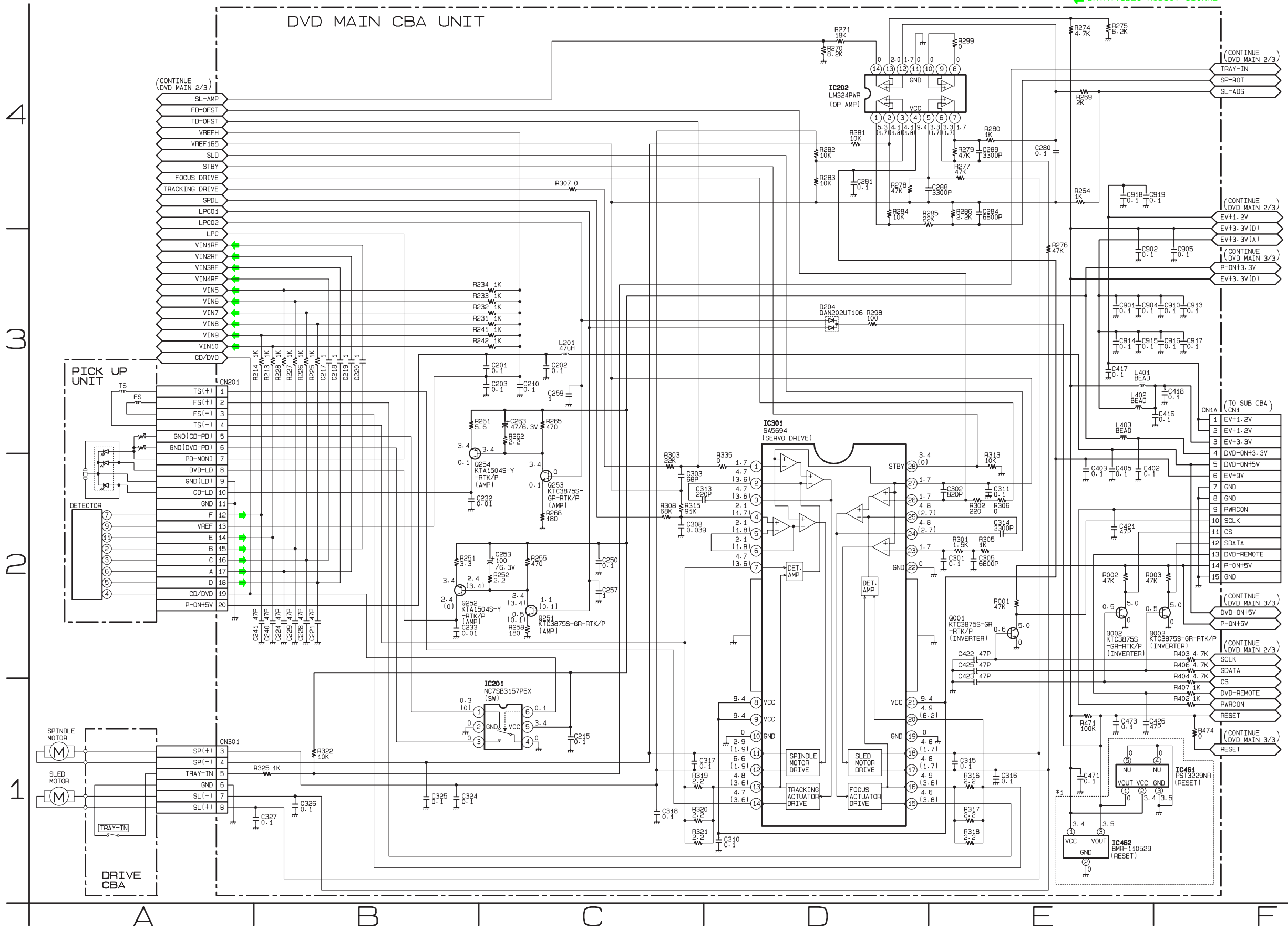

DVD MAIN 1/3	
Ref No.	Position
ICS	
IC201	C-1
IC202	D-4
IC301	D-3
IC461	F-1
IC462	E-1
TRANSISTORS	
Q001	E-2
Q002	E-2
Q003	E-2
Q251	C-2
Q252	B-2
Q253	C-2
Q254	C-2
CONNECTORS	
CN1A	F-3
CN201	A-3
CN301	A-1

DVD Main 2/3 Schematic Diagram < DVD Section >

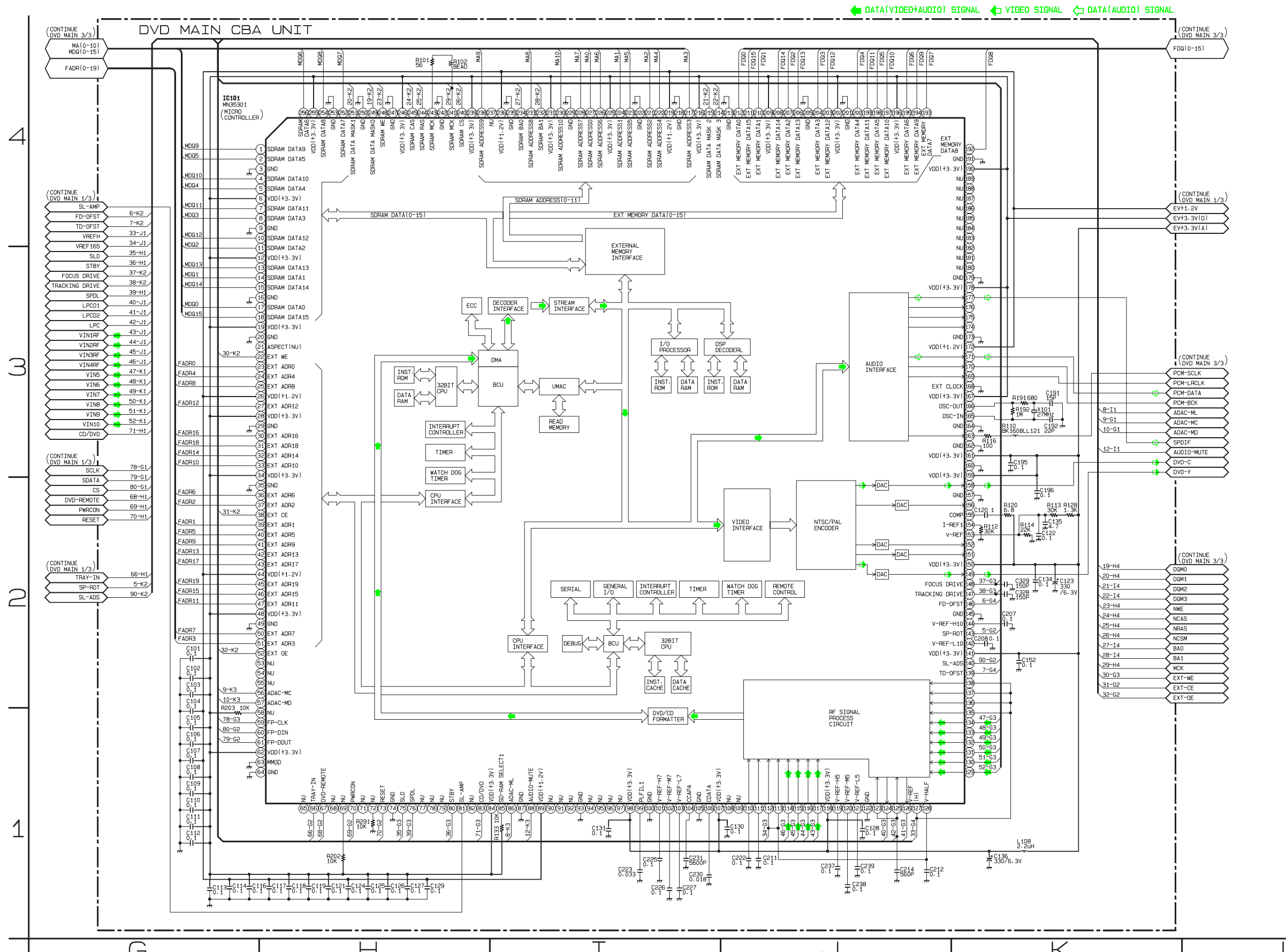

← DATA (VIDEO+AUDIO) SIGNAL ← VIDEO SIGNAL ← DATA (AUDIO) SIGNAL

DVD MAIN 2/3	
Ref No.	Position
IC	
IC101	G-4

IC101 Voltage Chart

~ : Voltage is not consistent ---- : Not used Unit : Volts

PIN.NO	PLAY	STOP	PIN.NO	PLAY	STOP	PIN.NO	PLAY	STOP	PIN.NO	PLAY	STOP	PIN.NO	PLAY	STOP	PIN.NO	PLAY	STOP	PIN.NO	PLAY	STOP	PIN.NO	PLAY	STOP
1	~	~	33	~	~	65	----	----	97	----	----	129	2.3	2.3	161	3.4	3.4	193	~	~	225	3.4	3.4
2	~	~	34	3.4	3.4	66	3.4	3.5	98	3.4	3.4	130	2.3	2.3	162	0	0	194	~	~	226	~	~
3	0	0	35	0	0	67	3.2	3.2	99	0.9	0.8	131	2.3	2.3	163	1.8	1.8	195	~	~	227	~	~
4	~	~	36	~	~	68	----	----	100	0	0	132	2.4	2.3	164	0	0	196	3.4	3.4	228	~	~
5	~	~	37	~	~	69	3.4	3.4	101	2.4	2.4	133	2.4	2.4	165	1.7	1.8	197	~	~	229	0	0
6	3.4	3.4	38	0.4	0.3	70	3.4	3.4	102	2.2	2.2	134	2.4	2.4	166	1.7	1.7	198	~	~	230	~	~
7	~	~	39	~	~	71	----	----	103	1.9	1.9	135	2.3	2.3	167	3.4	3.4	199	~	~	231	3.4	3.4
8	~	~	40	~	~	72	1.4	2.7	104	0.4	0.3	136	2.3	2.3	168	0	0	200	~	~	232	1.3	1.6
9	0	0	41	~	~	73	3.5	3.5	105	0	0	137	2.3	2.3	169	1.8	1.8	201	0	0	233	~	~
10	~	~	42	~	~	74	0	0	106	1.7	1.7	138	2.3	2.3	170	1.7	1.7	202	3.4	3.4	234	1.9	2.3
11	~	~	43	~	~	75	1.7	1.8	107	3.4	3.4	139	1.7	1.7	171	1.3	0.1	203	~	~	235	0	0
12	3.4	3.4	44	1.3	1.3	76	2.3	1.8	108	----	----	140	1.7	1.7	172	1.3	1.3	204	~	~	236	1.3	1.3
13	~	~	45	~	~	77	----	----	109	----	----	141	3.4	3.4	173	0	0	205	0	0	237	----	----
14	~	~	46	~	~	78	----	----	110	1.9	1.9	142	1.3	1.3	174	----	----	206	~	~	238	~	~
15	~	~	47	~	~	79	----	----	111	1.9	1.9	143	2.1	1.7	175	----	----	207	~	~	239	3.4	3.4
16	0	0	48	3.4	3.4	80	3.4	0	112	1.7	1.7	144	2.2	2.2	176	----	----	208	~	~	240	3.4	3.3
17	~	~	49	0	0	81	0.1	0.1	113	1.7	1.7	145	0	0	177	1.8	1.7	209	3.4	3.4	241	1.9	1.9
18	~	~	50	~	~	82	----	----	114	1.7	1.7	146	1.7	1.7	178	3.4	3.5	210	~	~	242	0	0
19	3.4	3.4	51	~	~	83	0.1	0.1	115	1.7	1.7	147	1.8	1.7	179	0	0	211	~	~	243	1.9	1.9
20	0	0	52	0.8	0.8	84	3.4	3.4	116	1.7	1.7	148	1.7	1.7	180	----	----	212	~	~	244	3.4	3.3
21	----	----	53	----	----	85	0.1	0.1	117	1.7	1.7	149	0.6	0.5	181	----	----	213	0	0	245	3.4	3.4
22	3.4	3.4	54	----	----	86	3.6	3.4	118	3.4	3.4	150	3.4	3.4	182	----	----	214	2.5	3.0	246	3.4	3.4
23	~	~	55	----	----	87	0	0	119	2.0	2.0	151	----	----	183	3.4	3.4	215	2.5	3.0	247	0	0
24	~	~	56	3.4	3.4	88	3.5	0.1	120	1.7	1.7	152	----	----	184	----	----	216	3.4	3.4	248	3.3	3.4
25	~	~	57	3.5	3.5	89	1.3	1.3	121	1.5	1.5	153	1.4	1.3	185	----	----	217	~	~	249	3.2	3
26	1.3	1.3	58	3.4	3.4	90	----	----	122	0	0	154	1.4	1.3	186	----	----	218	0	0	250	0	0
27	~	~	59	3.4	3.4	91	----	----	123	0.3	0.1	155	2.4	2.4	187	----	----	219	1.3	1.3	251	3.2	3.0
28	3.4	3.4	60	3.4	3.4	92	----	----	124	1.1	0.1	156	----	----	188	----	----	220	~	~	252	~	~
29	0	0	61	3.5	3.5	93	0	0	125	0.3	0.1	157	0	0	189	----	----	221	~	~	253	0	0
30	~	~	62	3.4	3.4	94	----	----	126	0.1	0.1	158	0.9	0.9	190	3.4	3.5	222	0	0	254	~	~
31	~	~	63	0	0	95	----	----	127	2.3	2.3	159	3.4	3.4	191	0	0	223	~	~	255	3.4	3.4
32	~	~	64	0	0	96	----	----	128	1.7	1.7	160	0	0	192	~	~	224	~	~	256	~	~

Main CBA Top View < TV/VCR Section >

Because a hot chassis ground is present in the power supply circuit, an isolation transformer must be used. Also, in order to have the ability to increase the input slowly, when troubleshooting this type power supply circuit, a variable isolation transformer is required.

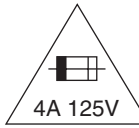

CAUTION ! : For continued protection against risk of fire, replace only with same type 4 A, 125V fuse.
ATTENTION : Utiliser un fusible de rechange de même type de 4A, 125V.

NOTE: The voltage for parts in hot circuit is measured using hot GND as a common terminal.

CAUTION !
 Fixed voltage (or Auto voltage selectable) power supply circuit is used in this unit. If Main Fuse (F1601) is blown, check to see that all components in the power supply circuit are not defective before you connect the AC plug to the AC power supply. Otherwise it may cause some components in the power supply circuit to fail.

Sensor CBA Top View

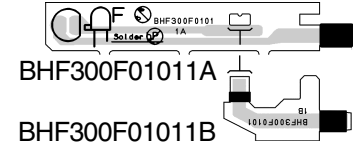

MAIN CBA

Ref No.	Position
ICS	
IC1001	F-1
IC1201	B-3
IC1202	B-4
IC1301	D-1
IC1401	C-3
IC1682	E-4
IC1701	C-5
IC1803	B-1
TRANSISTORS	
Q1205	A-4
Q1206	B-3
Q1221	E-4
Q1350	E-1
Q1401	C-3
Q1402	C-3
Q1403	C-3
Q1404	C-4
Q1601	F-2
Q1602	G-2
Q1604	G-3
Q1605	E-5
Q1606	F-5
Q1607	F-5
Q1609	E-5
Q1613	E-3
Q1614	D-4
Q1681	E-3
Q1682	E-4
Q1683	E-4
Q1688	E-4
Q1701	D-4
Q1871	D-3
Q1872	D-3
Q1873	D-3
Q1874	D-3
Q1875	D-3
CONNECTORS	
CL403	C-5
CL1201	D-1
CL1401	D-4
CL1402	D-2
CN1301	F-5
CN1302	F-5
CN1601	F-1
CN1602	G-5
CN1802	B-1
CN1803	A-5
TEST POINTS	
JM1403	D-5
TP1001	E-5
TP1002	E-5
TP1202	B-5
TP1301	E-5
TP1302	F-5
TP1303	E-5
TP1401	C-1
TP1402	B-5
TP1671	F-5
TP1672	F-5
TP1701	B-1
TP1702	C-1
TP1703	D-5
VARIABLE RESISTOR	
VR1601	G-4

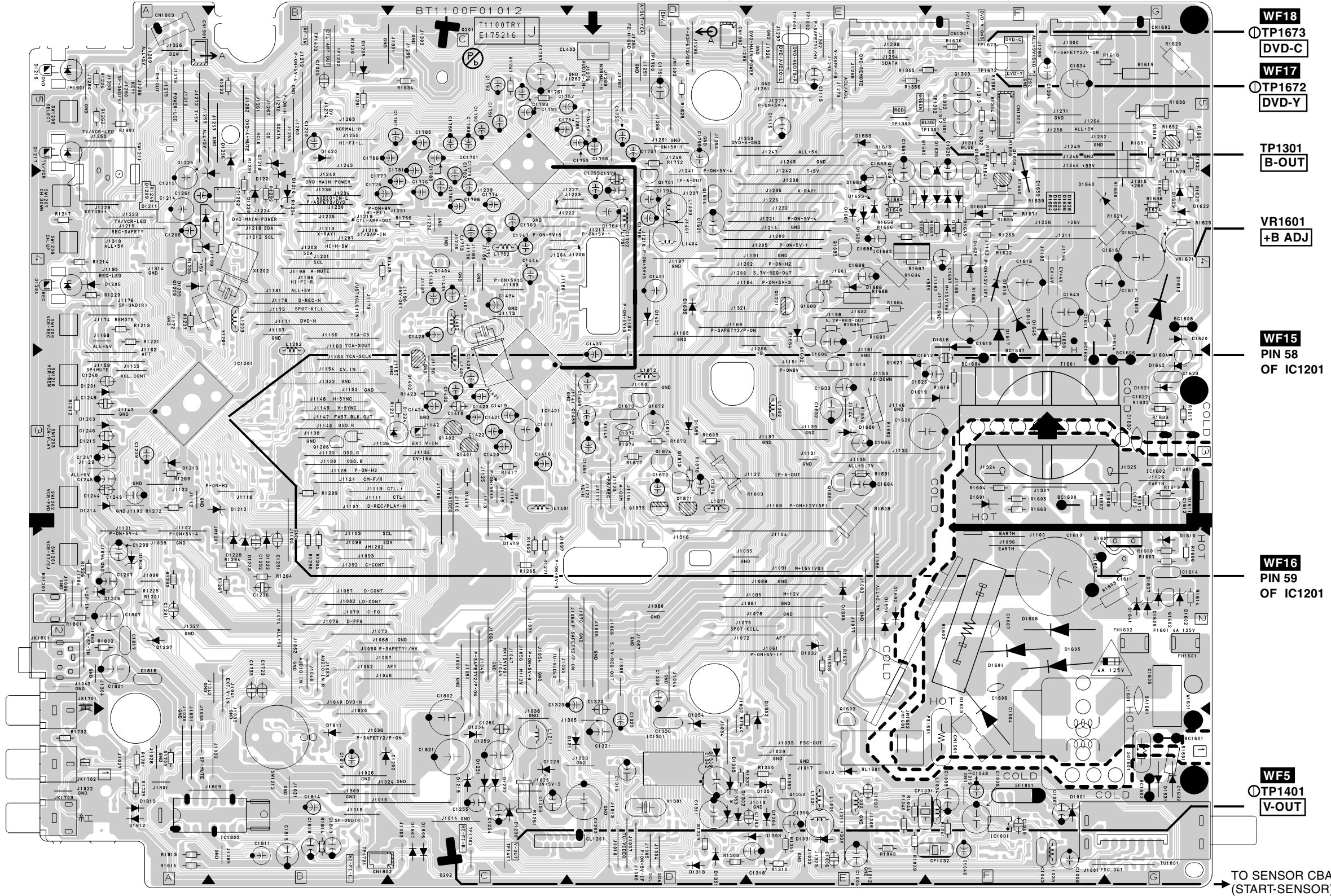

WF18
 TP1673
 DVD-C
 WF17
 TP1672
 DVD-Y

TP1301
 B-OUT

VR1601
 +B ADJ

WF15
 PIN 58
 OF IC1201

WF16
 PIN 59
 OF IC1201

WF5
 TP1401
 V-OUT

Main CBA Bottom View < TV/VCR Section >

Because a hot chassis ground is present in the power supply circuit, an isolation transformer must be used. Also, in order to have the ability to increase the input slowly, when troubleshooting this type power supply circuit, a variable isolation transformer is required.

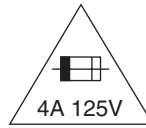

CAUTION ! : For continued protection against risk of fire, replace only with same type 4 A, 125V fuse.
ATTENTION : Utiliser un fusible de rechange de même type de 4A, 125V.

CAUTION !

Fixed voltage (or Auto voltage selectable) power supply circuit is used in this unit. If Main Fuse (F1601) is blown, check to see that all components in the power supply circuit are not defective before you connect the AC plug to the AC power supply. Otherwise it may cause some components in the power supply circuit to fail.

NOTE: The voltage for parts in hot circuit is measured using hot GND as a common terminal.

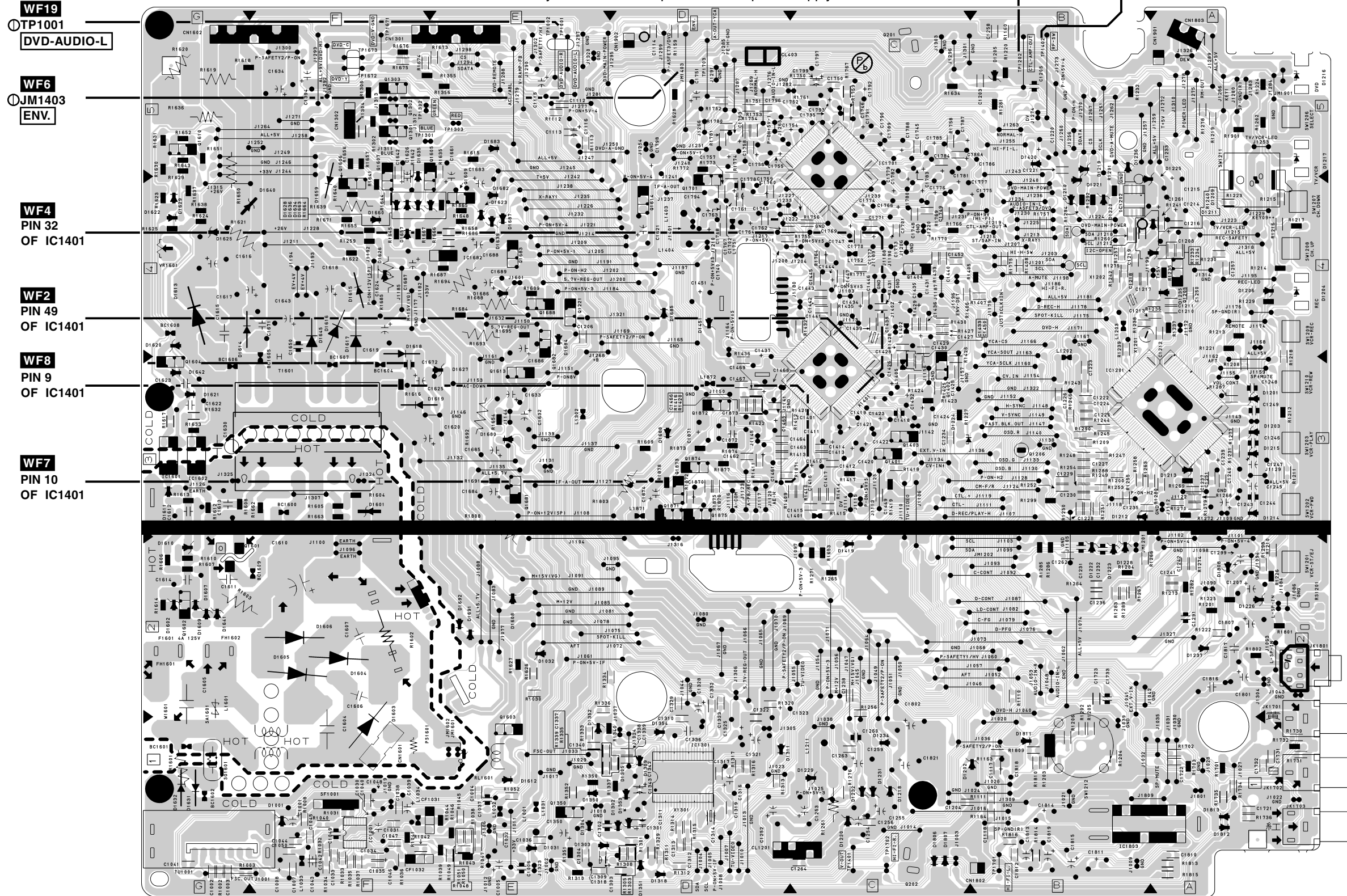

Sub CBA Top View < TV/VCR Section >

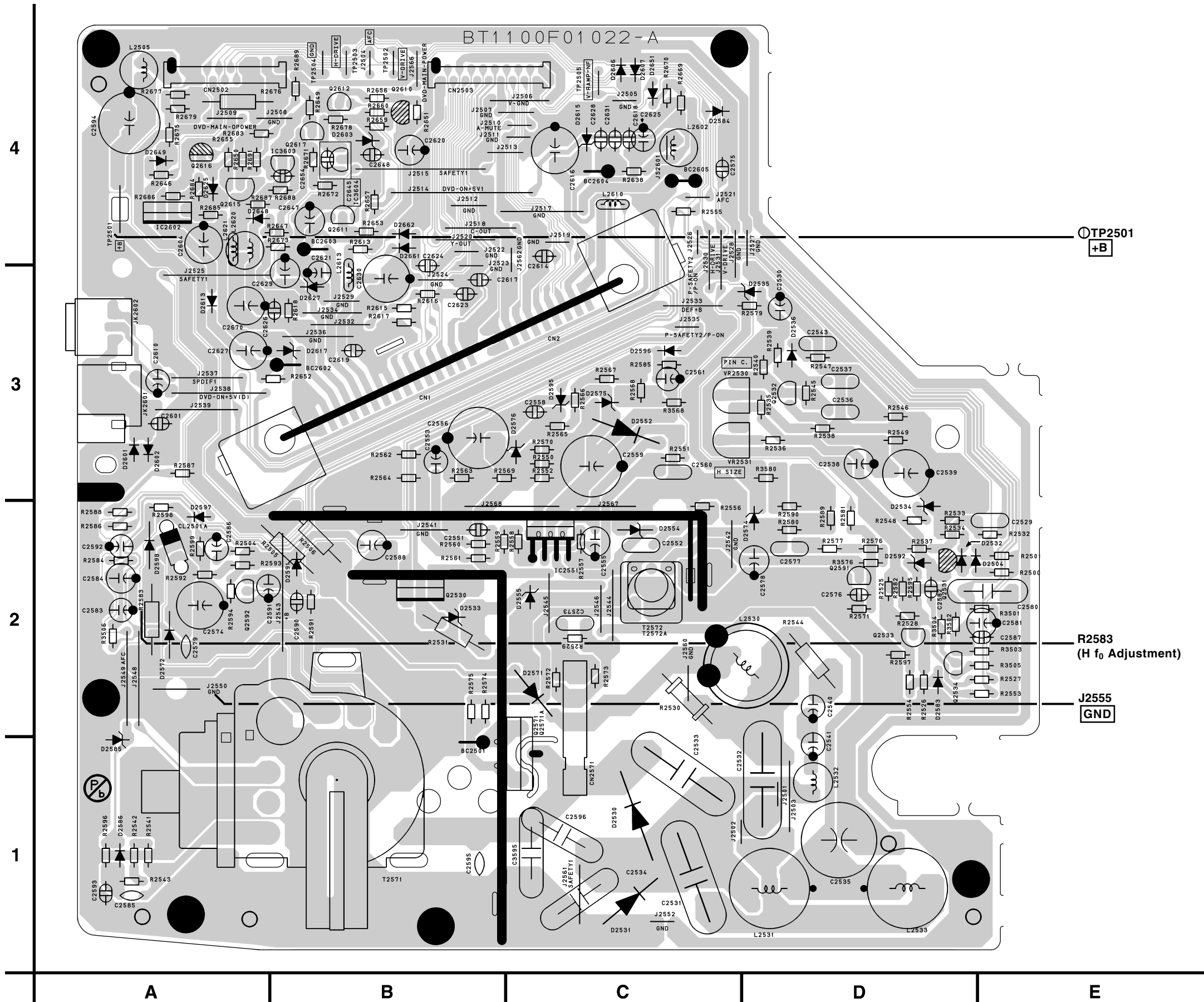

SUB CBA	
Ref No.	Position
ICS	
IC2551	C-2
IC2602	A-4
IC3603	B-4
IC3604	B-4
TRANSISTORS	
Q2571	C-2
Q2591	D-2
Q2592	A-2
Q2610	B-4
Q2611	B-4
Q2612	B-4
Q2615	A-4
Q2616	A-4
Q2617	B-4
CONNECTORS	
CL2501A	A-2
CN2502	A-4
CN2503	B-4
CN2571	C-1
CN1	B-3
CN2	C-3
TEST POINTS	
TP2501	A-4
TP2502	B-4
TP2503	B-4
TP2504	B-4
TP2505	C-4

Sub CBA Bottom View < TV/VCR Section >

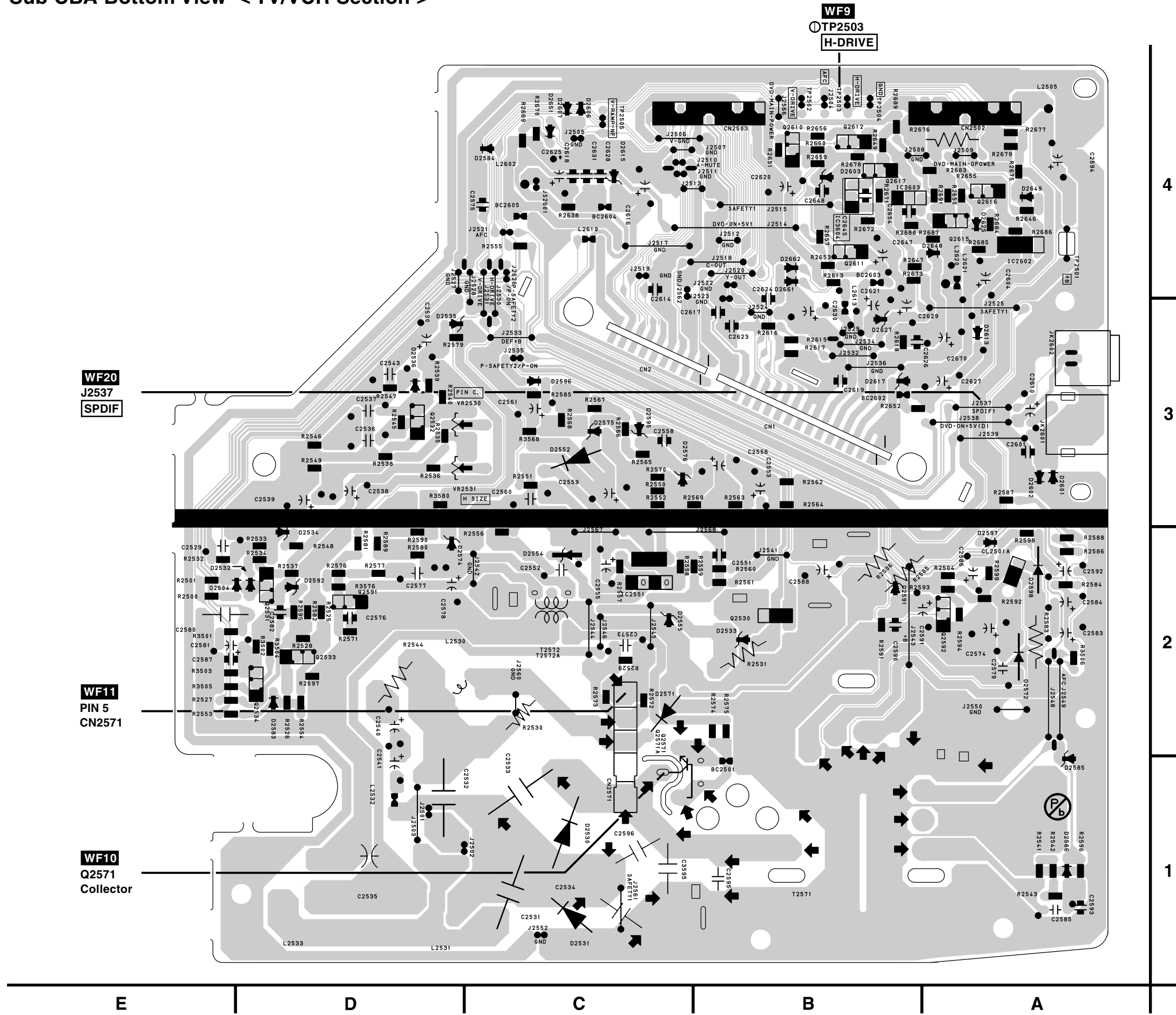

WF20
J2537
SPDIF

WF11
PIN 5
CN2571

WF10
Q2571
Collector

WF9
TP2503
H-DRIVE

4
3
2
1

E D C B A

CRT CBA Top View < TV/VCR Section >

CRT CBA Bottom View < TV/VCR Section >

CRT CBA

Ref No.	Position
TRANSISTORS	
Q2501	A-2
Q2502	A-2
Q2503	A-1
CONNECTORS	
CL2501B	B-1
CL2504A	A-2
CN2501	B-1

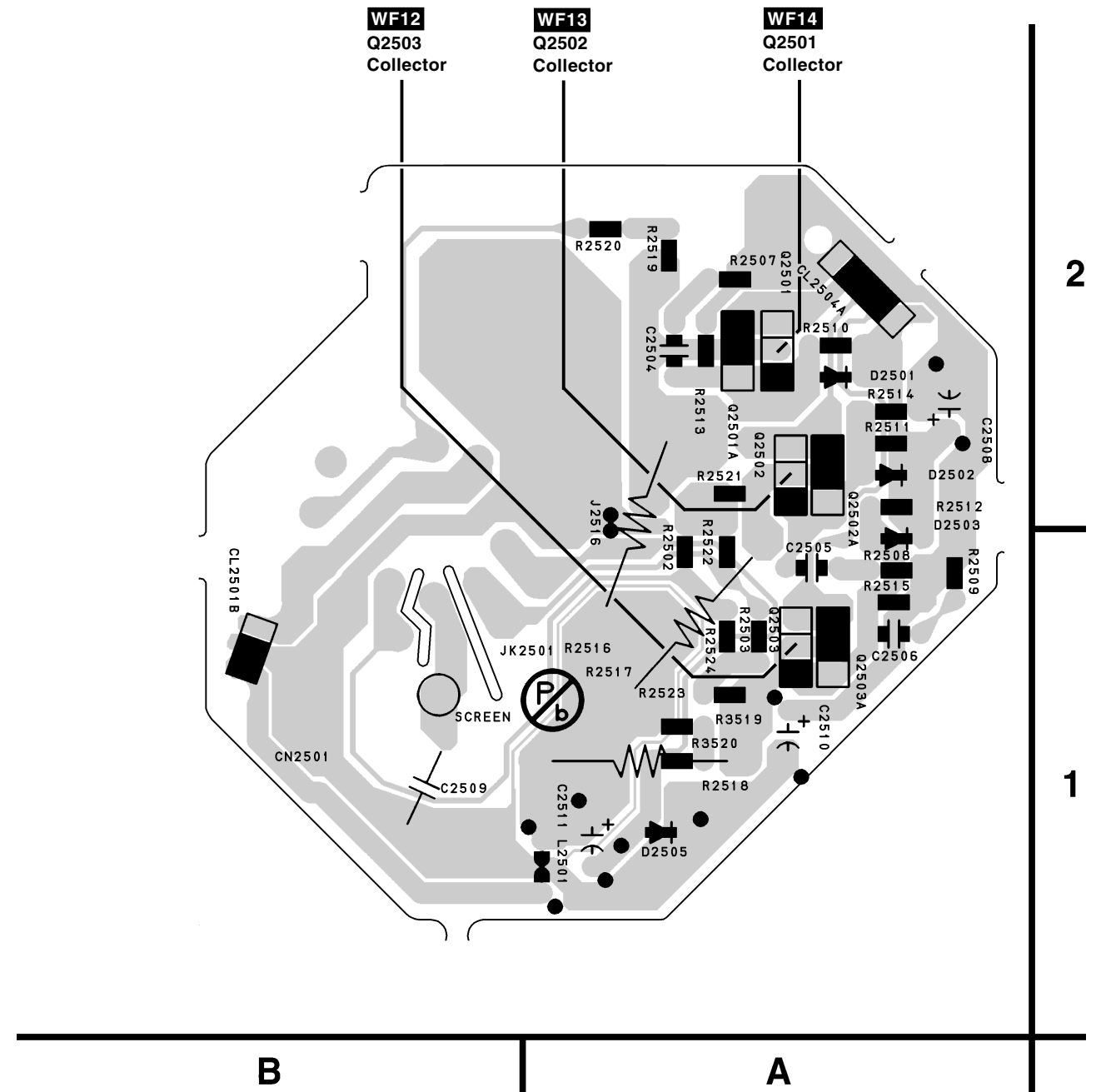
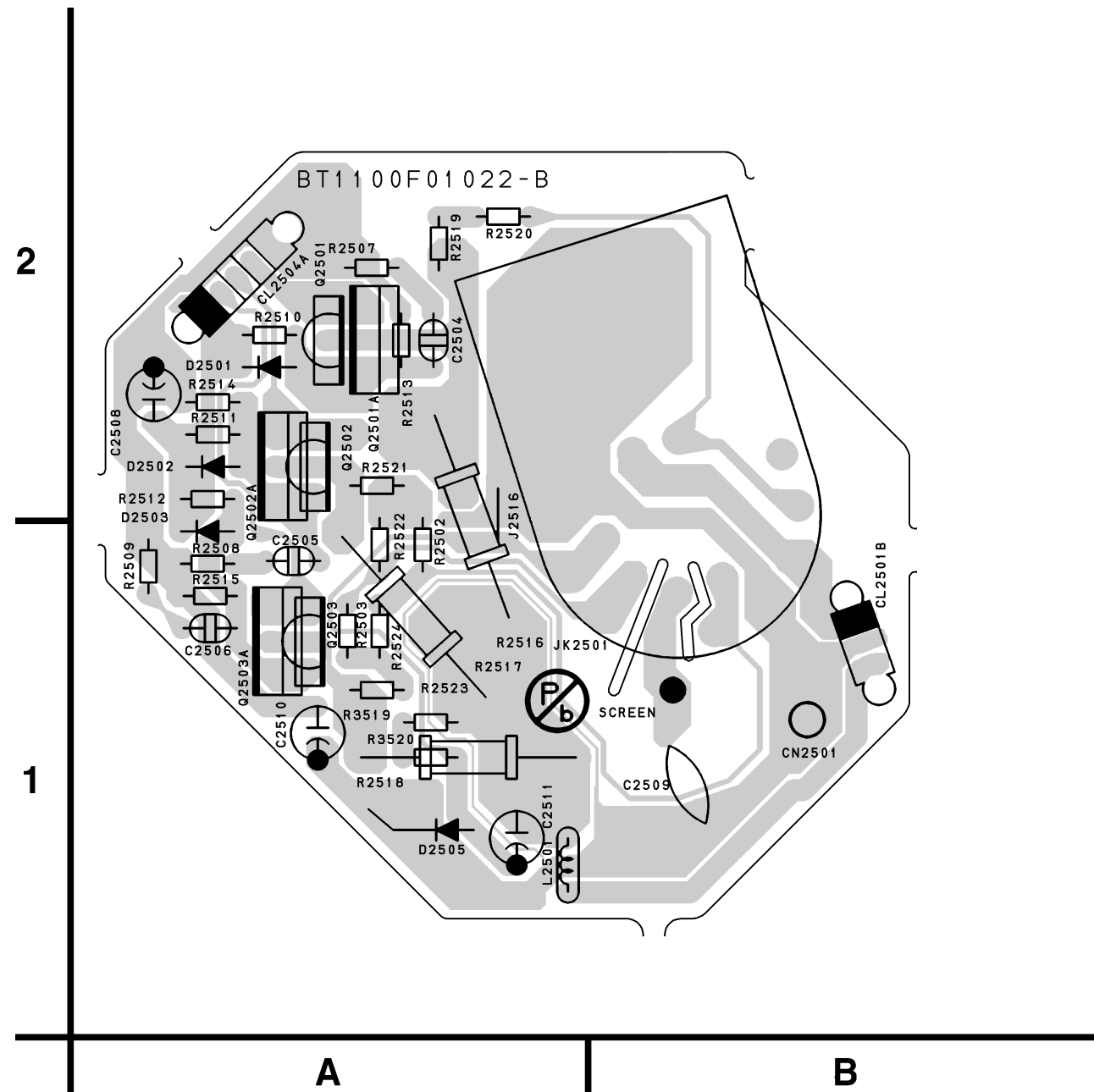

Function CBA Top View < TV/VCR Section >

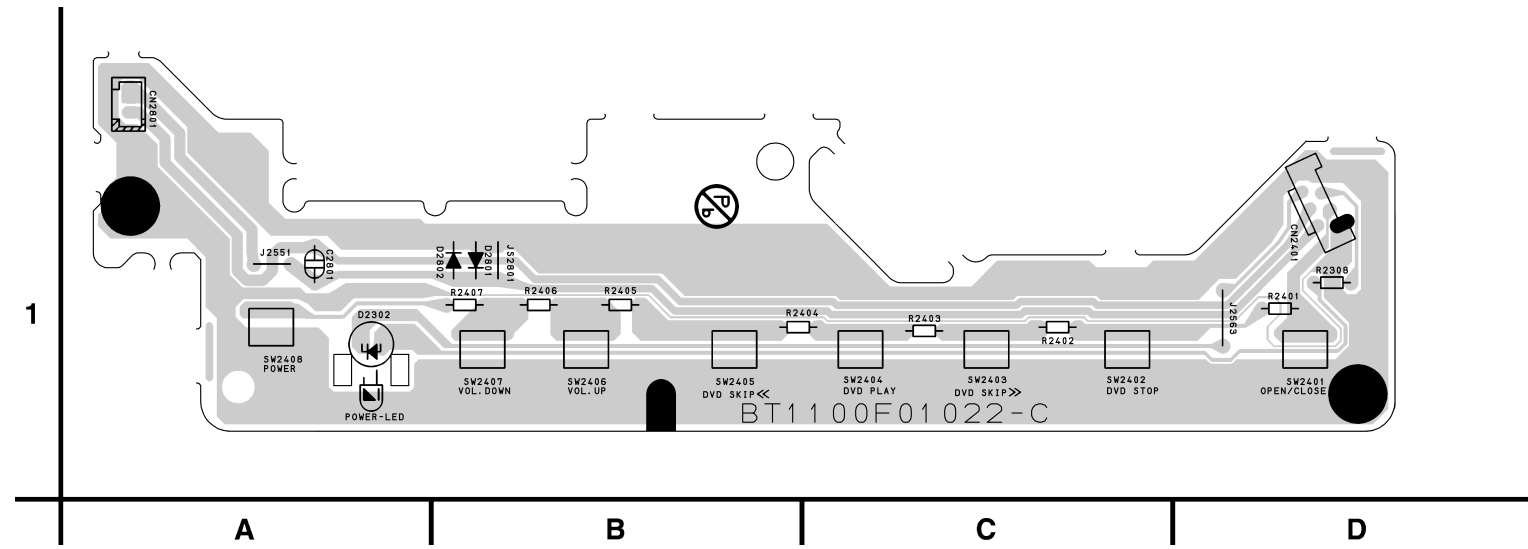

Function CBA Bottom View < TV/VCR Section >

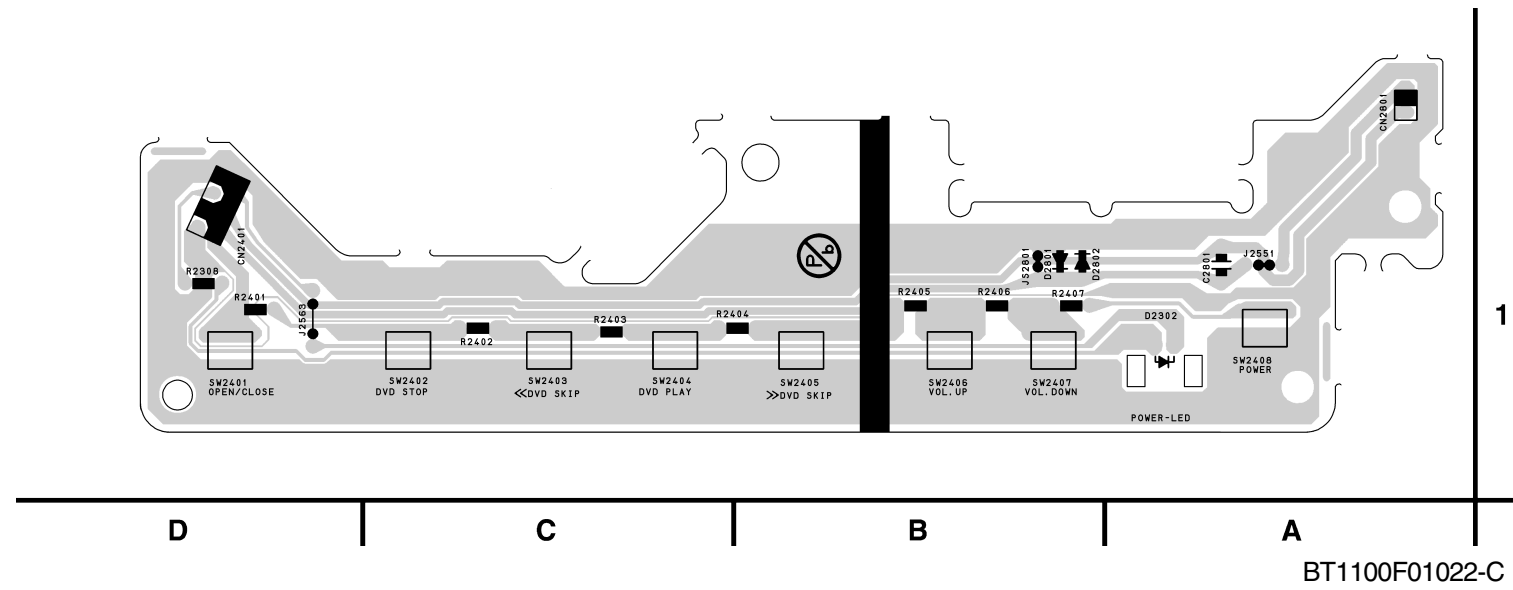

Junction CBA Top View

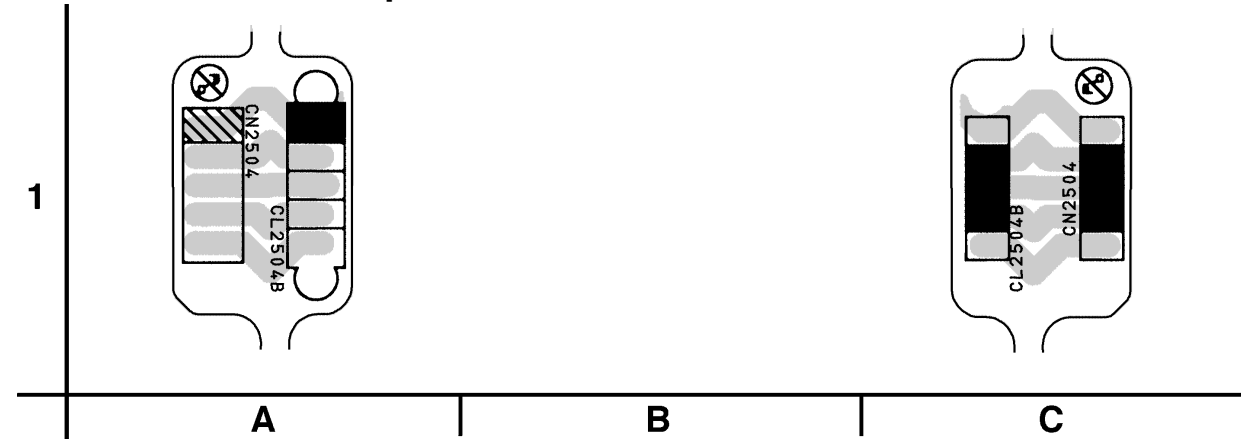

Junction CBA Bottom View

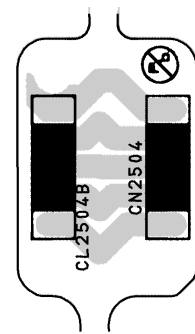

BT1100F01022

WAVEFORMS

Input:

NTSC Color Bar Signal (with 1kHz Audio Signal) --- WF1~WF16
 DVD Video (Power on (Stop) MODE) --- WF17, WF18
 CD (1KHz Play) --- WF19, WF20
INITIAL POSITION: Unplug unit from AC outlet for at least five minutes, reconnect to AC outlet and then turn power on.
 (Brightness---Center Color---Center Tint --- Center Contrast---Approx 70%)

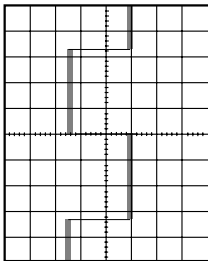

WF1 1DIV: 2V 5ms
 TP1402 RF-SW

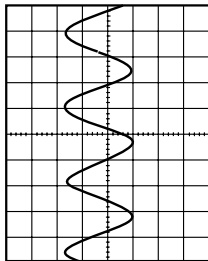

WF2 1DIV: 0.2V 0.1µs
 IC1401 Pin 49

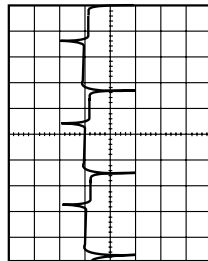

WF3 1DIV: 1V 10ms
 TP1202 CTL-AMP-OUT

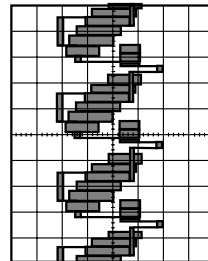

WF4 1DIV: 0.25V 20µs
 IC1401 Pin 32

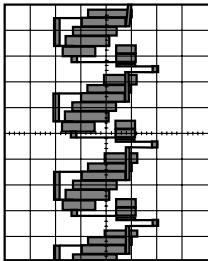

WF5 1DIV: 0.5V 20µs
 TP1401 V-OUT

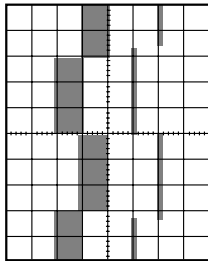

Upper: **WF6** Lower: **WF1**
 1DIV: 0.2V 2DIV: 5V 5ms
 JM1403 ENV.

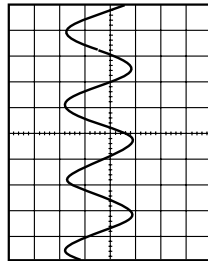

WF7 1DIV: 0.5V 0.5ms
 IC1401 PIN10

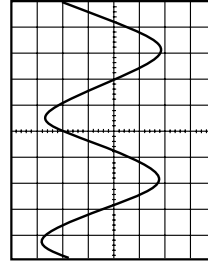

WF8 1DIV: 0.5V 0.5ms
 IC1401 PIN9

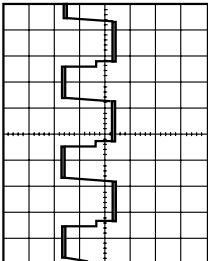

WF9 1DIV: 1V 20µs
 TP2503 H-DRIVE

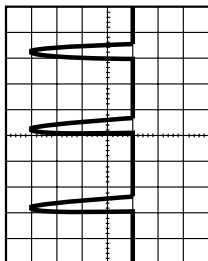

WF10 1DIV: 200V 20µs
 Q2571 COLLECTOR

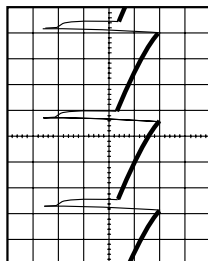

WF11 1DIV: 10V 5ms
 CN2571 PIN 5

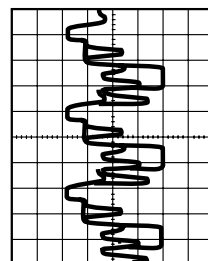

WF12 1DIV: 20V 20µs
 Q2503 COLLECTOR

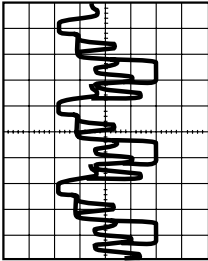

WF13 1DIV: 20V 20µs
 Q2502 COLLECTOR

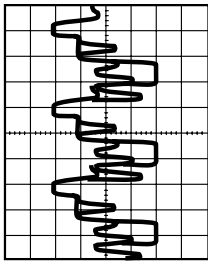

WF14 1DIV: 20V 20µs
 Q2501 COLLECTOR

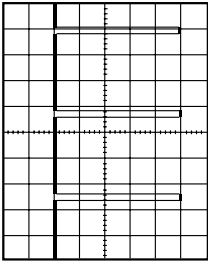

WF15 1DIV: 1V 20µs
 IC1201 PIN 58

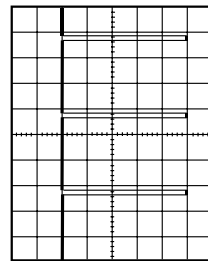

WF16 1DIV: 1V 5ms
 IC1201 PIN 59

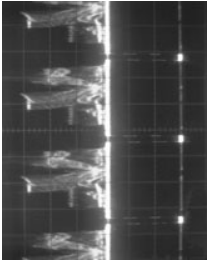

WF17 1DIV: 0.1V 20µs
 TP1672 DVD-Y

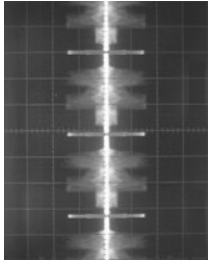

WF18 1DIV: 0.1V 20µs
 TP1673 DVD-C

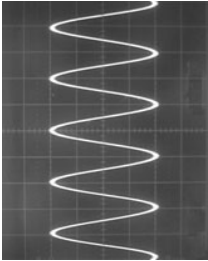

WF19 1DIV: 1V 0.5ms
 TP1001 DVD-AUDIO-L

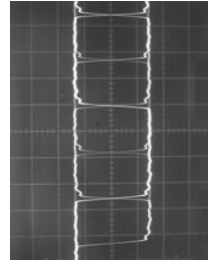

WF20 1DIV: 1V 0.1µs
 J2537 SPDIF

WIRING DIAGRAM < TV/VCR Section >

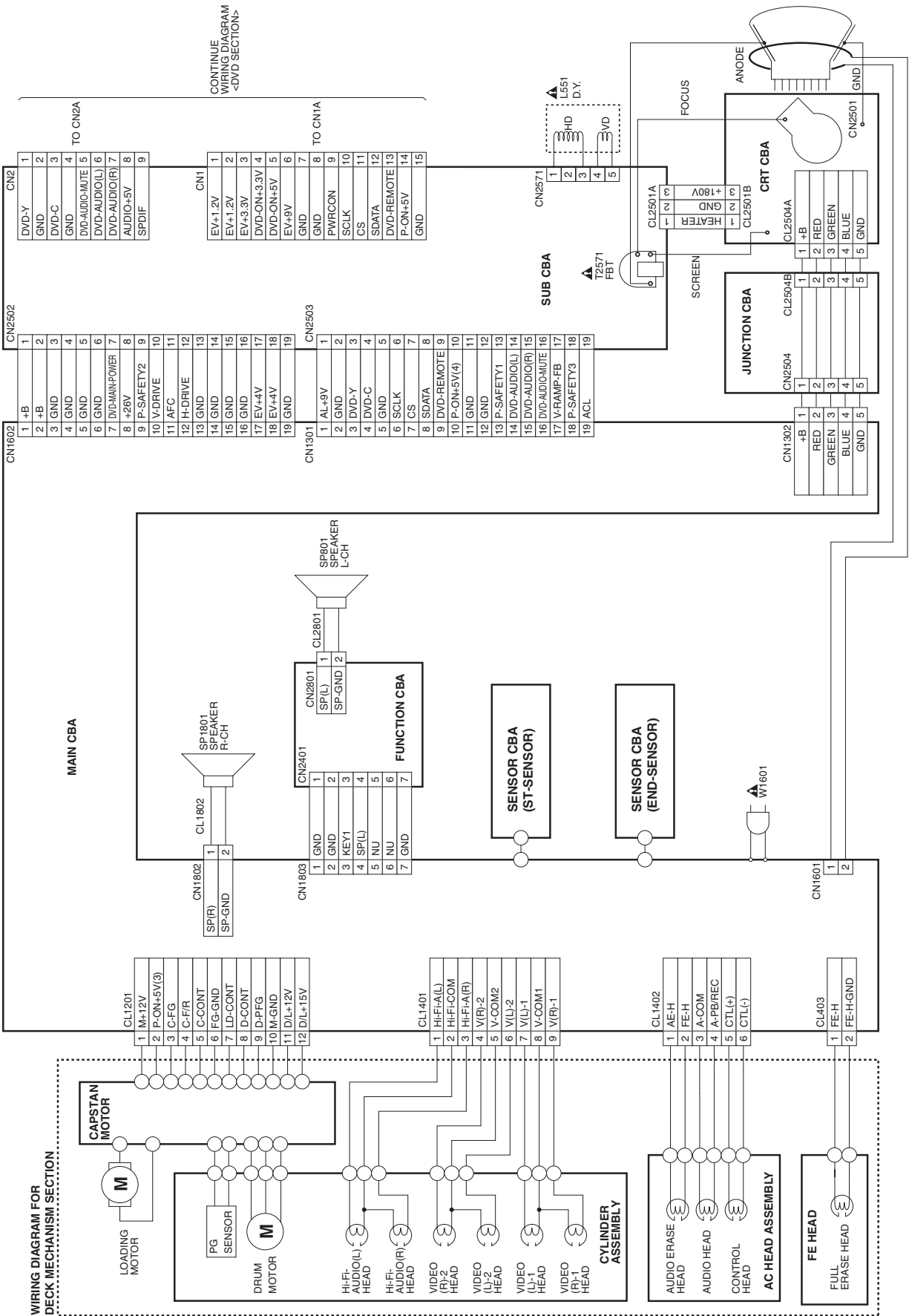

WIRING DIAGRAM < DVD Section >

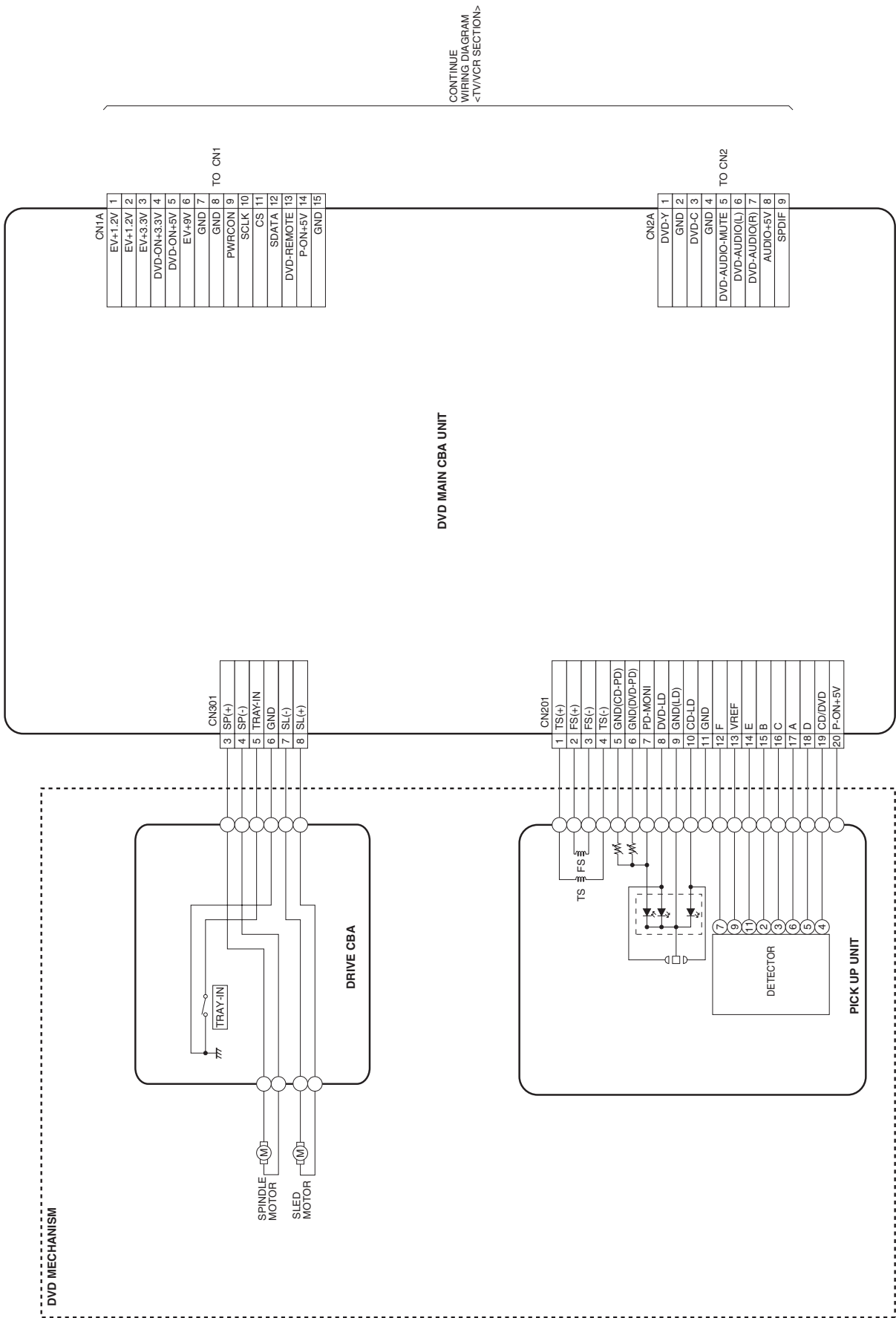

CONTINUE
WIRING DIAGRAM
<TV/VCR SECTION>

DVD MAIN CBA UNIT

DVD MECHANISM

SYSTEM CONTROL TIMING CHARTS

< VCR Section >

Mode SW: LD-SW

LD-SW Position detection A/D Input voltage Limit (Calculated voltage)	Symbol
3.76 V ~ 4.50 V (4.12 V)	EJ
4.51 V ~ 5.00 V (5.00 V)	CL
0.00 V ~ 0.25 V (0.00 V)	SB
1.06 V ~ 1.50 V (1.21 V)	TL
0.66 V ~ 1.05 V (0.91 V)	FB
1.99 V ~ 2.60 V (2.17 V)	SF
1.51 V ~ 1.98 V (1.80 V)	SM
3.20 V ~ 3.75 V (3.40 V)	AU
0.26 V ~ 0.65 V (0.44 V)	AL
4.51 V ~ 5.00 V (5.00 V)	SS
2.61 V ~ 3.19 V (2.97 V)	RS

↑
Note:

Note: EJ → RS: Loading FWD (LM-FWD / REV "H")
 RS → EJ: Loading REV (LM-FWD / REV "L")
 Stop (A) = Loading
 Stop (B) = Unloading

Note:

Symbol	Loading Status
EJ	Eject
CL	Eject ~ REW Reel
SB	REW Reel ~ Stop (B)
TL	Stop (B) ~ Brake Cancel
FB	Brake Cancel ~ FF / REW
SF	FF / REW ~ Stop (M), (FF / REW)
SM	Stop (M), (FF / REW) ~ Stop (A)
AU	Stop (A) ~ Play / REC
AL	Play / REC ~ Still / Slow
SS	Still / Slow ~ RS (REW Search)
RS	RS (REW Search)

Chart 1

1) SP MODE

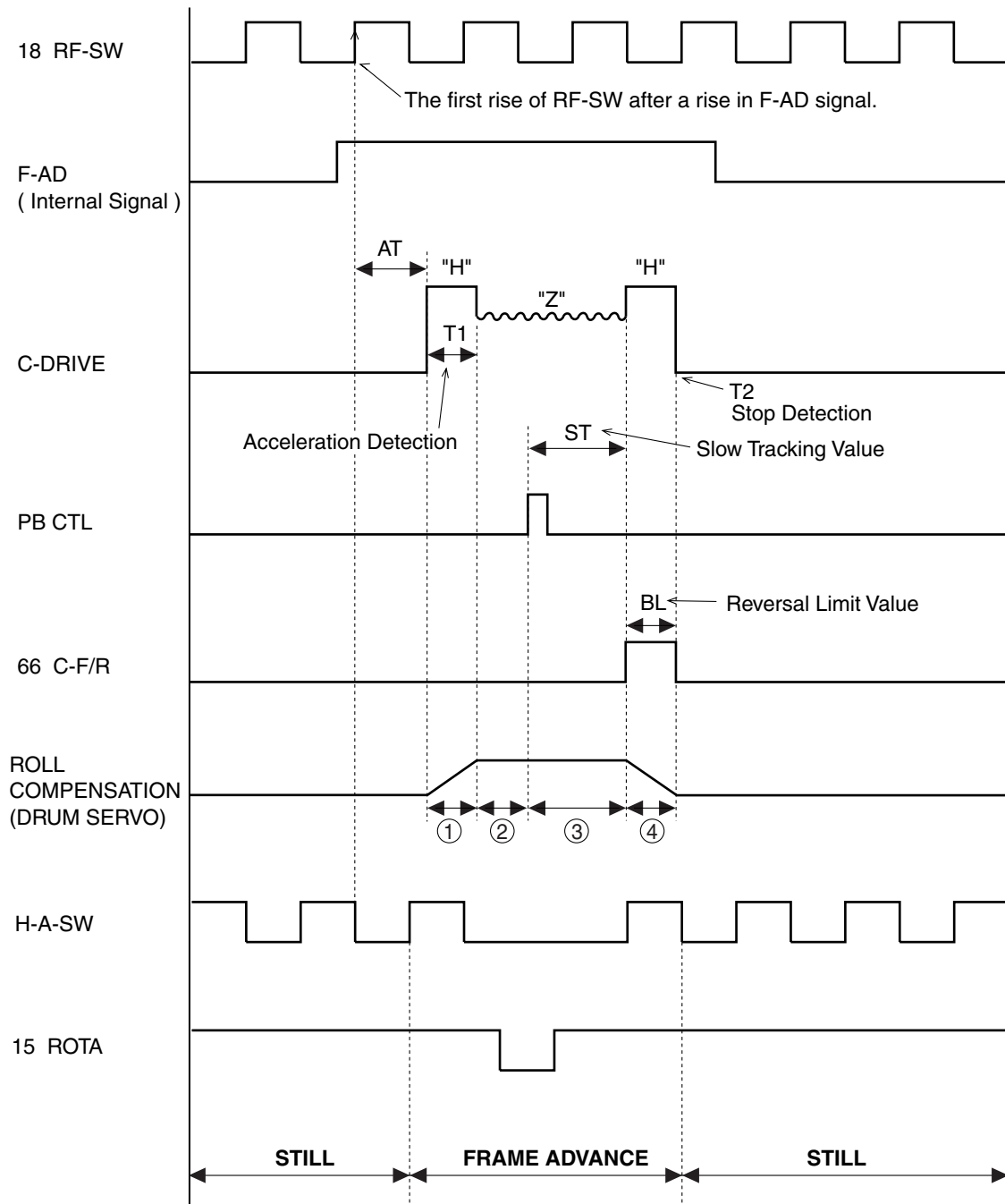
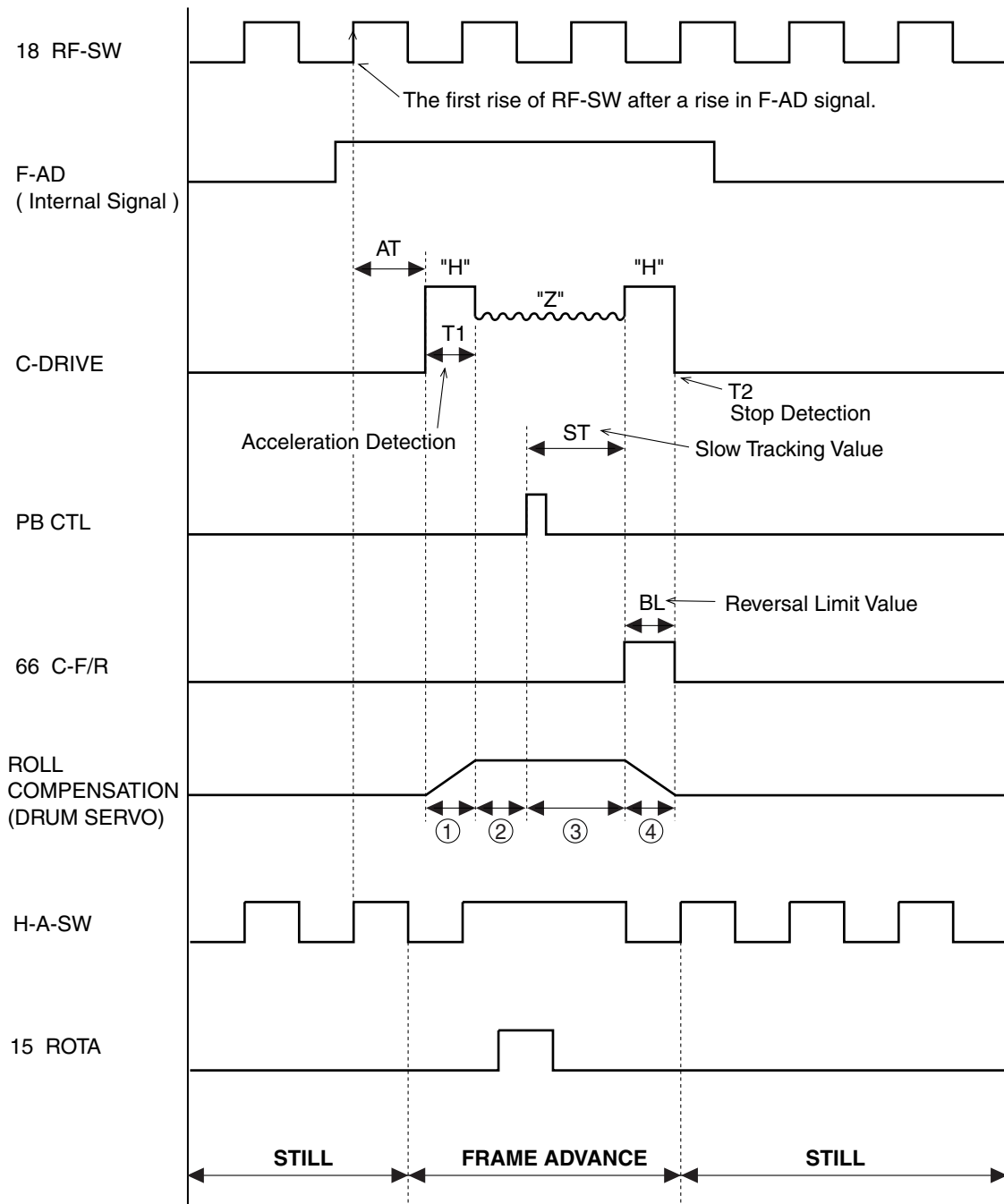

Chart 2

2) LP/EP MODE



< DVD Section >

Tray Close ~ Play / Play ~ Tray Open

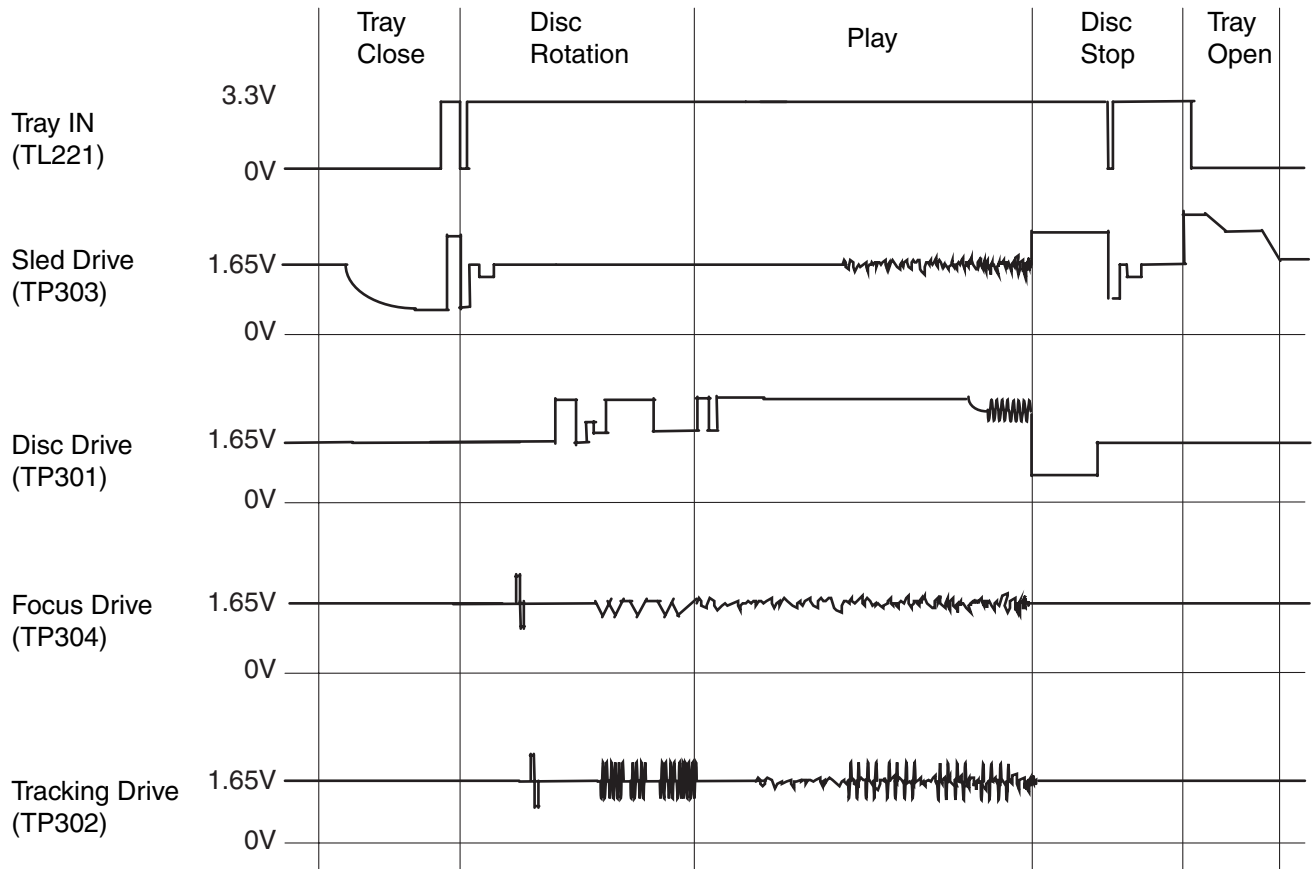

IC PIN FUNCTION DESCRIPTIONS

IC1201 (TV/VCR Micro Controller IC)

“H” ≥ 4.5 V, “L” ≤ 1.0 V

Pin No.	IN/OUT	Signal Name	Function
1	IN	LD-SW	Loading Switch Input
2	OUT	DVD-LED	DVD-LED Output
3	IN	P-SAFETY 2	Power Supply Failure Detection 2
4	IN	ST/SAP-IN	Tuner Stereo/Sap Detector Signal Input
5	IN	KEY0	Key 0 Input
6	IN	KEY1	Key 1 Input
7	IN	END-SENS	End-Sensor
8	IN	AFT	AFT Input
9	IN	ST-SENS	Start-Sensor
10	IN	V-ENV	Video Envelope Input
11	OUT	VOLUME	Volume Adjustment Output
12	OUT	SP-MUTE	Speaker Mute Output
13	OUT	DV-SYNC	Artificial V-Sync Output
14	IN	REMOTE	Remote Signal Input
15	OUT	ROTA	Color Phase Rotary Changeover Signal
16	OUT	V-H-SW	Video Head Amp Switching Pulse
17	IN	ENV-DET	Envelope Comparator Signal
18	OUT	RF-SW	Video Head Switching Pulse
19	OUT	Hi-Fi-H-SW	HiFi Audio Head Switching Pulse
20	OUT	D-PB-L	Output in Playback
21	OUT	REC-LED	Recording LED Control Signal
22	IN	NORMAL-H	Audio Mode Input Signal
23	OUT	ACL-CONT	ACL Control Signal
24	-	NU	Not Used
25	-	DVD-REMOTE	Remote Control Signal to DVD
26	OUT	TV/VCR-LED	TV/VCR Mode LED Control Signal
27	-	NU	Not Used
28	-	NU	Not Used
29	OUT	D-REC-H	Delayed Record Signal
30	-	NU	Not Used
31	OUT	P-ON-H	Power On Signal at High

Pin No.	IN/OUT	Signal Name	Function
32	-	NU	Not Used
33	IN	REC-SAFETY	Record Protection Tab Detection
34	IN	RESET	System Reset Signal (Reset = “L”)
35	IN	XC-IN	Sub Clock 32 kHz
36	OUT	XC-OUT	Sub Clock 32 kHz
37	-	TIMER+5V	Vcc
38	IN	X-IN	Main Clock Input
39	OUT	X-OUT	Main Clock Output
40	-	GND	GND
41	OUT	SPOT-KILL	Counter-measure for Spot
42	IN	DVD-MAIN-POWER	Power On Signal to High for DVD
43	IN	CLKSEL	Clock Select (GND)
44	OUT	D-REC-H	Delayed Record Signal
45	IN	I2C-OPEN	White Balance Adjust Mode Judgment
46	-	GND	GND
47	OUT	DVD-A-MUTE	DVD Audio Mute Signal
48	OUT	DVD-H	DVD at High
49	-	GND	OSD GND
50	-	CS	Chip Select
51	OUT	SCLK	HiFi Communication Clock
52	IN/OUT	SDATA	Serial Data
53	-	P-ON+5V	OSD Vcc
54	-	HLF	HLF
55	IN	V-HOLD	VHOLD
56	IN	CV-IN	Video Signal Input
57	-	GND	GND
58	IN	H-SYNC	H-SYNC Input
59	IN	V-SYNC	V-SYNC Input
60	OUT	OSD-BLK	Output for Picture Cut off
61	-	NU	Not Used
62	OUT	OSD-B	Blue Output
63	OUT	OSD-G	Green Output
64	OUT	OSD-R	Red Output
65	OUT	A-MUTE	Audio Mute Output
66	OUT	C-F/R	Capstan Motor FWD/REV Control Signal

Pin No.	IN/ OUT	Signal Name	Function
67	OUT	D-REC-L/ PLAY-H	Recording/Playback Output
68	OUT	YCA-SDA	YCA IC Control Data
69	OUT	YCA-CS	YCA IC Control Chip Select
70	OUT	YCA-SCL	YCA IC Control Clock
71	OUT	SCL	E2PROM/CHROMA IC Tuner Communication Clock
72	IN/ OUT	SDA	E2PROM/CHROMA IC Tuner Communication Data
73	-	NU	Not Used
74	IN	C-SYNC	C-Sync Input
75	-	NU	Not Used
76	OUT	C-CONT	Capstan Motor Control Signal
77	OUT	D-CONT	Drum Motor Control Signal
78	IN	P-SAFETY 3	Power Supply Failure Detection 3
79	-	NU	Not Used
80	IN	T-REEL	Take Up Reel Rotation Signal
81	-	NU	Not Used
82	OUT	LD-CONT	Loading Motor Control Signal
83	-	NU	Not Used
84	IN	P-DOWN	Power Voltage Down Detector Signal
85	-	NU	Not Used
86	-	NU	Not Used
87	IN	C-FG	Capstan Motor Rotation Detection Pulse
88	-	GND	GND (AMP)
89	-	NU	Not Used
90	IN	D-PFG	Drum Motor Pulse Generator
91	-	NU	Not Used
92	OUT	AMP- VREF- IN	Standard Voltage Input
93	-	C	C
94	IN/ OUT	CTL (-)	CTL (-)
95	IN/ OUT	CTL (+)	CTL (+)
96	-	AMPC	AMPC
97	OUT	CTL-AMP- OUT	Control Amp Output
98	-	P-ON+5V	Power Supply for AMP
99	-	AL+5V	A/D, D/A Standard Voltage

Pin No.	IN/ OUT	Signal Name	Function
100	IN	P-SAFETY 1	Power Supply Failure Detection 1

LEAD IDENTIFICATIONS

2SK3563

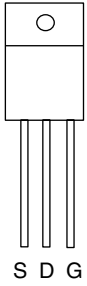

MID-32A22F

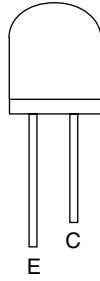

AN17812A

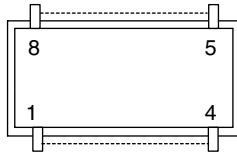

2SD400(F)

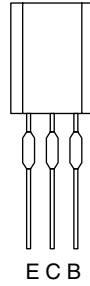

PQ070XF01SZ

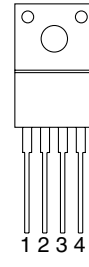

1: Vin
2: Vo
3: GND
4: Vc

LA78040A

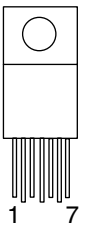

2SC2120-O-TPE2

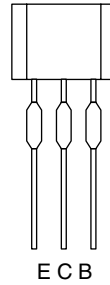
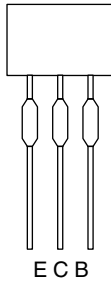

2SA1175(F)
2SA950(O)
2SC1627Y-TPE2
2SC2482 TPE6
2SC2785(F)
2SC3331(T)
KRA103M
KRC103M
KTC3199(GR)

KIA7805API

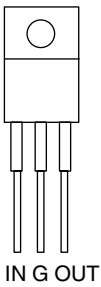

KIA431-AT

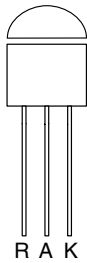

TT2140LS-YB11

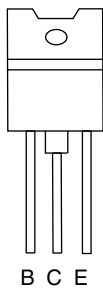

LTV-817C-F



M3776AMCH-BA2GP

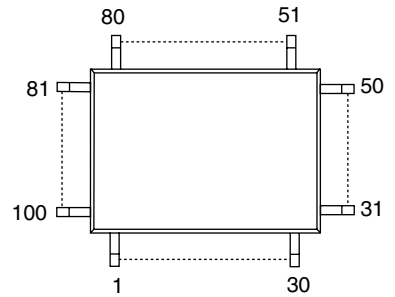

M61116FP TF0G

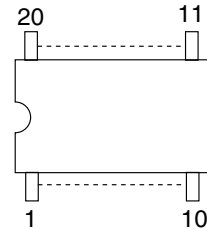

LA71205M-MPB-E
LA72670M-A-MPB-E

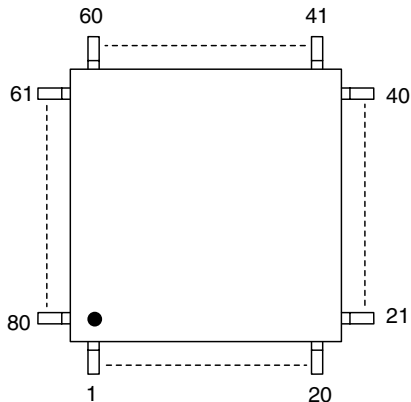

BR24C02F-W

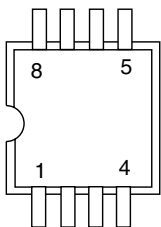

M61275FP TF1H

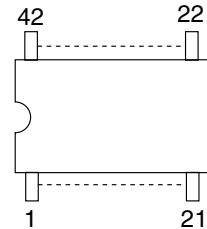

Note:

A: Anode
K: Cathode
E: Emitter
C: Collector
B: Base
R: Reference
S: Source
G: Gate
D: Drain

EXPLODED VIEWS

Cabinet

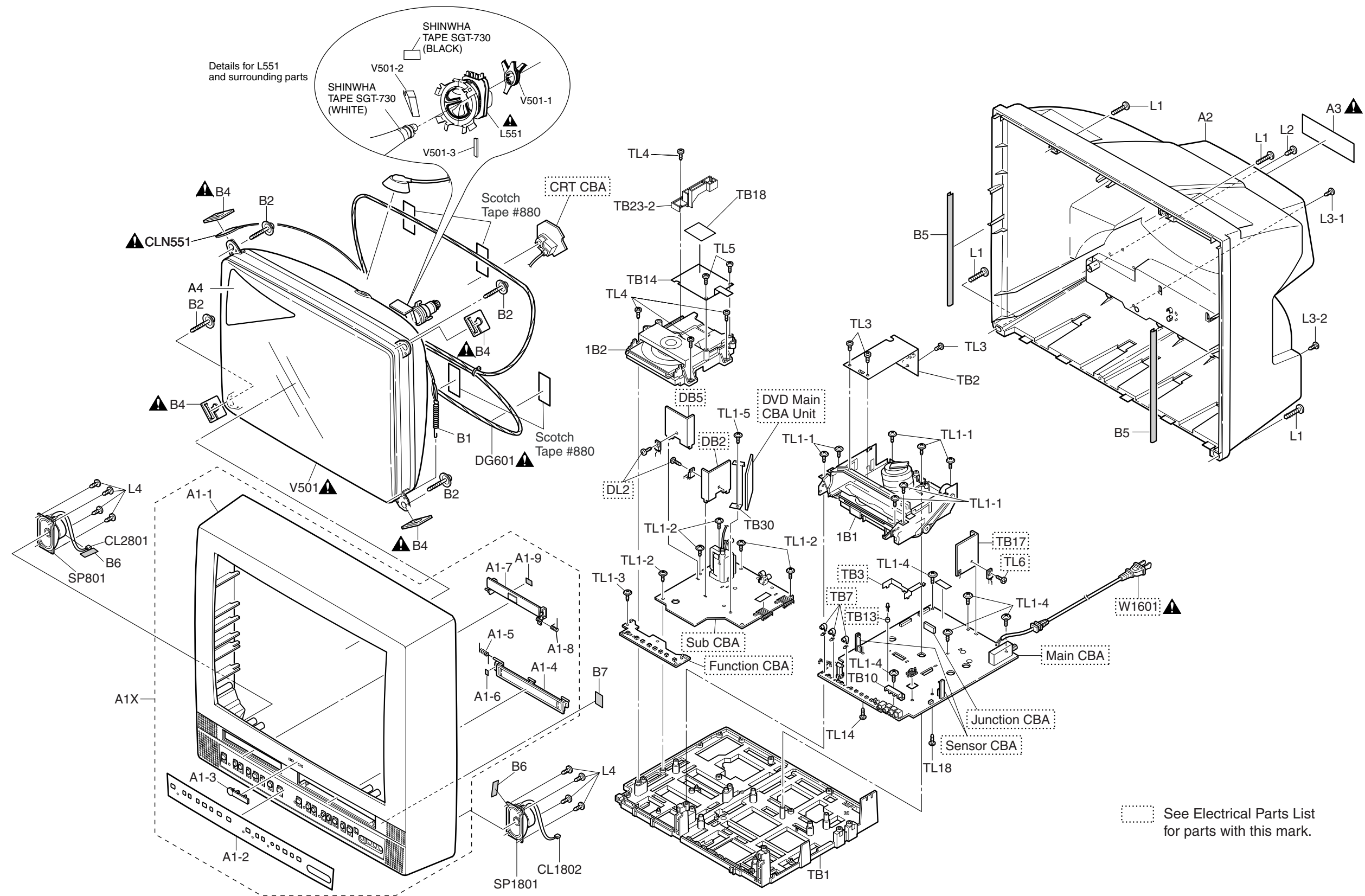



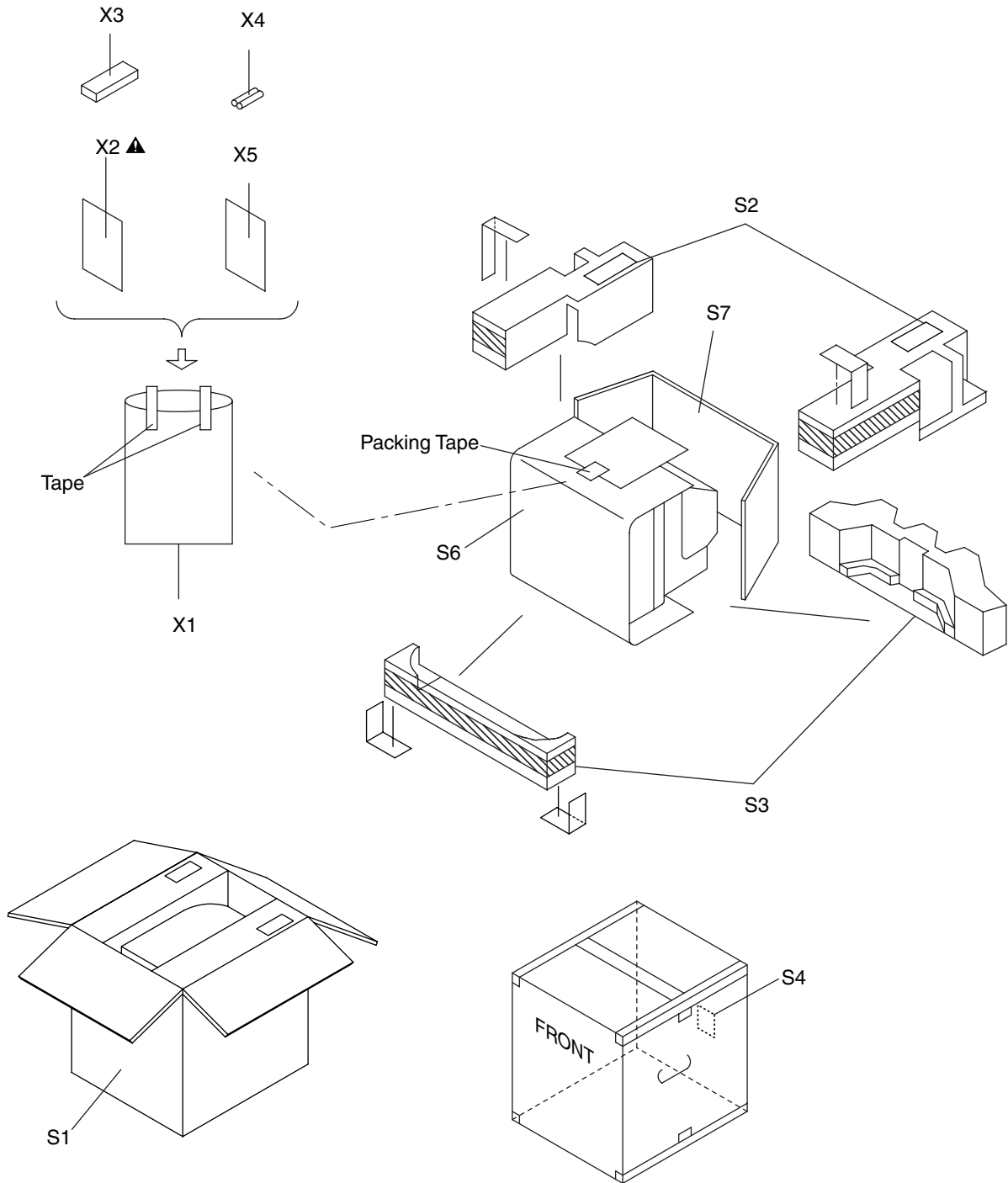

Packing



MECHANICAL PARTS LIST

PRODUCT SAFETY NOTE: Products marked with a  have special characteristics important to safety. Before replacing any of these components, read carefully the product safety notice in this service manual. Don't degrade the safety of the product through improper servicing.

NOTE: Parts that are not assigned part numbers (-----) are not available.

Ref. No.	Description	Part No.
A1X	FRONT CABINET ASSEMBLY T1100UA	1EM120103
A1-1	FRONT CABINET T1050UA	1EM020067
A1-2	CONTROL PLATE T1100UA	1EM220076
A1-3	BADGE L BRAND TD951UB~SYLVANIA~	0EM408107
A1-4	CASSETTE DOOR TD851UB	0EM408098
A1-5	SPRING DOOR(Z10) T5200UA	0EM406687
A1-6	CLOTH(4X7XT0.7) T5000UA	0EM404974
A1-7	TRAY PANEL (X4-T19) TD853UD	0EM301854A
A1-8	TRAY SPRING TD707UH	0EM408552
A1-9	CLOTH(B) L5201U0:15X10X1.0T	0EM400076
A2	REAR CABINET T1050UA	1EM020066
A3 	RATING LABEL T1100UA	-----
A4	POP LABEL T1100UA	-----
1B1	DECK ASSEMBLY CZD014/VM2466	N2466FT
1B2	DVD MECHA E6(TRP-COMBO) N79U0JVM	N79U0JVM
B1	SPRING TENSION B0080B0:EM40808	26WH006
B2	SCREW L1500UA	0EM406142
B4 	DEGAUSS HOLDER L2401UB	1EM420205
B5	CLOTH 190X15XT0.5	TS7623
B6	CLOTH(10X30XT0.5) B5900UA	0EM404486
B7	CLOTH(15X10XT0.5) L9700UA	0EM405038
CL1802	WIRE ASSEMBLY SPEAKER WIRE(180MM)	WX1L9800-001
CL2801	WIRE ASSEMBLY SPEAKER WIRE(180MM)	WX1L9800-001
CLN551 	CRT WIRE WX1T7180-005	WX1T7180-005
DG601 	DEGAUSSING COIL F-054	LLBH00ZTM054
L1	SCREW, P-TIGHT 4X18 BIND HEAD +	GBMP4180
L2	SCREW TAPPING M4X14	DBU14140
L3-1	SCREW, P-TIGHT 3X10 BIND HEAD+	GBKP3100
L3-2	SCREW, P-TIGHT 3X10 BIND HEAD+	GBKP3100
L4	SCREW, P-TIGHT 3X10 BIND HEAD+	GBMP3100
L551 	DEFLECTION YOKE LLBY00ZSY010	LLBY00ZSY010
SP801	SPEAKER S0407F01A	DSD0807XQ001
SP1801	SPEAKER S0407F01A	DSD0807XQ001
TB1	TRAY CHASSIS T1100UA	1EM020114
TB2	TOP SHIELD T1100UA	1EM320155
TB10	RCA HOLDER T1100UA	1EM420613
TB14	X6 LOADER COVER T1100UA	1EM420561
TB18	LABEL, LASER CAUTION (C) TD100UA	-----
TB23-2	WIRE HOLDER C T1100UA	1EM420615
TB30	X6 LOADER PCB HOLDER T1100UA	1EM420560
TL1-1	SCREW, P-TIGHT 3X12 WASHER HEAD+	GCMP3120
TL1-2	SCREW, P-TIGHT 3X12 WASHER HEAD+	GCMP3120
TL1-3	SCREW, P-TIGHT 3X12 WASHER HEAD+	GCMP3120
TL1-4	SCREW, P-TIGHT 3X12 WASHER HEAD+	GCMP3120
TL1-5	SCREW, P-TIGHT 3X12 WASHER HEAD+	GCMP3120
TL3	SCREW, S-TIGHT 3X4 BIND HEAD+	GBMS3040
TL4	SCREW, P-TIGHT 3X16 BIND HEAD +	GBMP3160
TL5	P-TIGHT SCREW 3X8 BIND +	GBMP3080

Ref. No.	Description	Part No.
TL14	SCREW, B-TIGHT D3X8 BIND HEAD+	GBMB3080
TL18	SCREW, P-TIGHT M3X8 BIND HEAD+	GBCP3080
V501 	CRT A51MAJ196X	TCRT190PTD02
V501-1	C.PMAGNET JH225-FN-00	XM04000BV003
V501-2	WEDGE FT-00110W	XV10000T4001
V501-3	RUBBER MAGNET 20X10X1.2	XM05000BV001
PACKING		
S1	CARTON T1100UA	1EM420644
S2	STYROFOAM TOP ASSEMBLY T1050UA	1EM420308
S3	STYROFOAM BOTTOM ASSEMBLY T1050UA	1EM420309
S4	SERIAL NO. LABEL T1100UA	-----
S6	SET SHEET B7500UA:1000X1700	0EM402178
S7	HOLD PAD T1100UA	1EM420618
ACCESSORIES		
X1	BAG POLYETHYLENE 235X365XT0.03	0EM408420
X2 	OWNER'S MANUAL T1100UA	1EMN20212
X3	REMOTE CONTROL 189/ERC001/NE209UD	NE209UD
X4	DRY BATTERY R6P(AR)2PX	XB0M451HU002

ELECTRICAL PARTS LIST

PRODUCT SAFETY NOTE: Products marked with a  have special characteristics important to safety. Before replacing any of these components, read carefully the product safety notice in this service manual. Don't degrade the safety of the product through improper servicing.

NOTES:

- Parts that are not assigned part numbers (-----) are not available.
- Tolerance of Capacitors and Resistors are noted with the following symbols.

C.....±0.25% D.....±0.5% F.....±1%
 G.....±2% J.....±5% K.....±10%
 M.....±20% N.....±30% Z.....+80/-20%

DVD MAIN CBA UNIT

Ref. No.	Description	Part No.
	DVD MAIN CBA UNIT	N79U1JUP

MMA CBA

Ref. No.	Description	Part No.
	MMA CBA Consists of the following:	1ESA10432
	MAIN CBA SENSOR CBA	----- 1ESA10448

MAIN CBA

Ref. No.	Description	Part No.
	MAIN CBA Consists of the following:	-----
CAPACITORS		
C1001	ELECTROLYTIC CAP. 4.7µF/50V M	CE1JMASDL4R7
C1002	CHIP CERAMIC CAP. CH J 180pF/50V	CHD1JJ3CH181
C1003	CHIP CERAMIC CAP. CH J 180pF/50V	CHD1JJ3CH181
C1004	CHIP CERAMIC CAP. F Z 0.01µF/50V	CHD1JZ30F103
C1005	ELECTROLYTIC CAP. 220µF/6.3V M	CE0KMASDL221
C1007	CHIP CERAMIC CAP.(1608) B K 0.01µF/50V	CHD1JK30B103
C1008	ELECTROLYTIC CAP. 10µF/50V M H7	CE1JMAVSL100
C1030	ELECTROLYTIC CAP. 470µF/6.3V M	CE0KMASDL471
C1031	CHIP CERAMIC CAP.(1608) B K 0.01µF/50V	CHD1JK30B103
C1034	CHIP CERAMIC CAP.(1608) B K 1000pF/50V	CHD1JK30B102
C1035	CHIP CERAMIC CAP. F Z 1µF/10V	CHD1AZ30F105
C1037	CERAMIC CAP.(AX) F Z 0.01µF/50V	CA1J103TU014
C1038	CHIP CERAMIC CAP. F Z 0.01µF/50V	CHD1JZ30F103
C1040	CHIP CERAMIC CAP.(1608) B K 0.01µF/50V	CHD1JK30B103
C1041	CHIP CERAMIC CAP.(1608) B K 0.01µF/50V	CHD1JK30B103
C1043	FILM CAP.(P) 0.018µF/50V J	CMA1JJS00183
C1044	CHIP CERAMIC CAP.(1608) B K 0.047µF/50V	CHD1JK30B473
C1045	CHIP CERAMIC CAP. C J C 3.3pF/50V	CHD1JC3CJ3R3
C1046	ELECTROLYTIC CAP. 1µF/50V M H7	CE1JMAVSL1R0
C1049	CERAMIC CAP.(AX) CH K 2.7pF/50V	CCA1JKTCH2R7
C1050	CHIP CERAMIC CAP.(1608) CH D 5.6pF/50V	CHD1JD3CH5R6
C1112	CHIP CERAMIC CAP.(1608) B K 1000pF/50V	CHD1JK30B102
C1113	CHIP CERAMIC CAP.(1608) B K 1000pF/50V	CHD1JK30B102

Ref. No.	Description	Part No.
C1114	CHIP CERAMIC CAP.(1608) B K 1000pF/50V	CHD1JK30B102
C1115	PCB JUMPER D0.6-P5.0	JW5.0T
C1116	ELECTROLYTIC CAP. 47µF/25V M	CE1EMASDL470
C1117	CHIP CERAMIC CAP.(1608) B K 5600pF/50V	CHD1JK30B562
C1118	CHIP CERAMIC CAP.(1608) B K 5600pF/50V	CHD1JK30B562
C1203	CHIP CERAMIC CAP.(1608) F Z 0.1µF/50V	CHD1JZ30F104
C1207	ELECTROLYTIC CAP. 47µF/25V M	CE1EMASDL470
C1208	ELECTROLYTIC CAP. 47µF/6.3V M H7	CE0KMAVSL470
C1210	CHIP CERAMIC CAP. F Z 1µF/10V	CHD1AZ30F105
C1211	CHIP CERAMIC CAP.(1608) B K 0.022µF/50V	CHD1JK30B223
C1212	CHIP CERAMIC CAP.(1608) CH J 22pF/50V	CHD1JJ3CH220
C1213	CHIP CERAMIC CAP.(1608) CH J 22pF/50V	CHD1JJ3CH220
C1214	ELECTROLYTIC CAP. 47µF/6.3V M H7	CE0KMAVSL470
C1216	CHIP CERAMIC CAP.(1608) B K 0.01µF/50V	CHD1JK30B103
C1217	CHIP CERAMIC CAP.(1608) CH D 10pF/50V	CHD1JD3CH100
C1218	CHIP CERAMIC CAP. CH J 15pF/50V	CHD1JJ3CH150
C1219	CHIP CERAMIC CAP.(1608) B K 0.01µF/50V	CHD1JK30B103
C1220	ELECTROLYTIC CAP. 47µF/6.3V M H7	CE0KMAVSL470
C1221	CHIP CERAMIC CAP.(1608) B K 0.01µF/50V	CHD1JK30B103
C1222	CHIP CERAMIC CAP. B K 2200pF/50V	CHD1JK30B222
C1223	CHIP CERAMIC CAP. F Z 1µF/10V	CHD1AZ30F105
C1224	CHIP CERAMIC CAP.(1608) B K 1000pF/50V	CHD1JK30B102
C1225	CHIP CERAMIC CAP. CH J 560pF/50V	CHD1JJ3CH561
C1226	CHIP CERAMIC CAP.(1608) B K 1000pF/50V	CHD1JK30B102
C1233	CHIP CERAMIC CAP.(1608) B K 0.01µF/50V	CHD1JK30B103
C1234	CHIP CERAMIC CAP. F Z 1µF/10V	CHD1AZ30F105
C1235	CHIP CERAMIC CAP.(1608) B K 0.022µF/50V	CHD1JK30B223
C1239	ELECTROLYTIC CAP. 22µF/16V M H7	CE1CMAVSL220
C1240	CHIP CERAMIC CAP. CH J 560pF/50V	CHD1JJ3CH561
C1241	CHIP CERAMIC CAP.(1608) B K 4700pF/50V	CHD1JK30B472
C1243	ELECTROLYTIC CAP. 22µF/16V M LL	CE1CMASLL220
C1244	CERAMIC CAP.(AX) Y M 0.01µF/16V	CCA1CMT0Y103
C1245	ELECTROLYTIC CAP. 47µF/25V M	CE1EMASDL470
C1246	CERAMIC CAP.(AX) Y M 0.01µF/16V	CCA1CMT0Y103
C1247	ELECTROLYTIC CAP. 22µF/50V M	CE1JMASDL220
C1249	CERAMIC CAP.(AX) Y M 0.01µF/16V	CCA1CMT0Y103
C1251	CHIP CERAMIC CAP.(1608) B K 2700pF/50V	CHD1JK30B272
C1252	ELECTROLYTIC CAP. 470µF/16V M	CE1CMASDL471
C1253	ELECTROLYTIC CAP. 100µF/10V M	CE1AMASDL101
C1254	ELECTROLYTIC CAP. 47µF/25V M	CE1EMASDL470
C1257	CHIP CERAMIC CAP.(1608) B K 0.01µF/50V	CHD1JK30B103
C1258	CHIP CERAMIC CAP.(1608) B K 0.01µF/50V	CHD1JK30B103
C1261	ELECTROLYTIC CAP. 22µF/16V M H7	CE1CMAVSL220
C1264	CHIP CERAMIC CAP. F Z 0.047µF/50V	CHD1JZ30F473
C1299	ELECTROLYTIC CAP. 4.7µF/50V M	CE1JMASDL4R7
C1301	CHIP CERAMIC CAP. F Z 0.01µF/50V	CHD1JZ30F103
C1309	CHIP CERAMIC CAP. F Z 1µF/10V	CHD1AZ30F105
C1310	CHIP CERAMIC CAP. F Z 1µF/10V	CHD1AZ30F105
C1311	ELECTROLYTIC CAP. 470µF/10V M	CE1AMASDL471
C1314	CHIP CERAMIC CAP.(1608) B K 0.01µF/50V	CHD1JK30B103
C1316	ELECTROLYTIC CAP. 2.2µF/50V M	CE1JMASDL2R2
C1317	CHIP CERAMIC CAP.(1608) B K 0.01µF/50V	CHD1JK30B103
C1318	ELECTROLYTIC CAP. 100µF/10V M	CE1AMASDL101
C1319	CHIP CERAMIC CAP. F Z 1µF/10V	CHD1AZ30F105
C1321	ELECTROLYTIC CAP. 330µF/6.3V M	CE0KMASDL331
C1322	CERAMIC CAP.(AX) Y M 0.01µF/16V	CCA1CMT0Y103
C1323	ELECTROLYTIC CAP. 1µF/50V M H7	CE1JMAVSL1R0
C1325	ELECTROLYTIC CAP. 1µF/50V M H7	CE1JMAVSL1R0
C1332	CHIP CERAMIC CAP. F Z 1µF/10V	CHD1AZ30F105
C1333	CHIP CERAMIC CAP. F Z 1µF/10V	CHD1AZ30F105

Ref. No.	Description	Part No.
C1336	STACKED FILM CAP. 0.47μF/50V J	CMA1JJS00474
C1337	CHIP CERAMIC CAP.(1608) B K 0.01μF/50V	CHD1JK30B103
C1338	CHIP CERAMIC CAP. F Z 2.2μF/10V	CHD1AZ30F225
C1339	CHIP CERAMIC CAP.(1608) B K 0.01μF/50V	CHD1JK30B103
C1342	ELECTROLYTIC CAP. 470μF/10V M	CE1AMASDL471
C1343	CHIP CERAMIC CAP.(1608) B K 0.01μF/50V	CHD1JK30B103
C1350	ELECTROLYTIC CAP. 22μF/50V M	CE1JMASDL220
C1394	PCB JUMPER D0.6-P5.0	JW5.0T
C1410	ELECTROLYTIC CAP. 1μF/50V M H7	CE1JMAVSL1R0
C1411	ELECTROLYTIC CAP. 100μF/10V M H7	CE1AMAVSL101
C1412	CHIP CERAMIC CAP. F Z 0.01μF/50V	CHD1JZ30F103
C1413	CHIP CERAMIC CAP.(1608) CH J 390pF/50V	CHD1JJ3CH391
C1414	CHIP RES.(1608) 1/10W 0 Ω	RRXAZR5Z0000
C1417	CHIP CERAMIC CAP. CH J 220pF/50V	CHD1JJ3CH221
C1418	CERAMIC CAP.(AX) B K 0.1μF/50V	CA1J104TU011
C1419	ELECTROLYTIC CAP. 1μF/50V M H7	CE1JMAVSL1R0
C1420	ELECTROLYTIC CAP. 22μF/16V M H7	CE1CMAVSL220
C1421	ELECTROLYTIC CAP. 4.7μF/50V M H7	CE1JMAVSL4R7
C1422	ELECTROLYTIC CAP. 1μF/50V M H7	CE1JMAVSL1R0
C1423	ELECTROLYTIC CAP. 4.7μF/50V M H7	CE1JMAVSL4R7
C1424	ELECTROLYTIC CAP. 1μF/50V M H7	CE1JMAVSL1R0
C1425	CHIP CERAMIC CAP. F Z 1μF/10V	CHD1AZ30F105
C1426	ELECTROLYTIC CAP. 22μF/16V M H7	CE1CMAVSL220
C1427	CHIP CERAMIC CAP.(1608) B K 0.01μF/50V	CHD1JK30B103
C1428	CHIP CERAMIC CAP.(1608) B K 0.01μF/50V	CHD1JK30B103
C1429	ELECTROLYTIC CAP. 47μF/6.3V M H7	CE0KMAVSL470
C1430	CHIP CERAMIC CAP.(1608) B K 0.022μF/50V	CHD1JK30B223
C1431	ELECTROLYTIC CAP. 1μF/50V M H7	CE1JMAVSL1R0
C1432	ELECTROLYTIC CAP. 1μF/50V M H7	CE1JMAVSL1R0
C1433	CHIP CERAMIC CAP.(1608) B K 0.01μF/50V	CHD1JK30B103
C1435	ELECTROLYTIC CAP. 1μF/50V M H7	CE1JMAVSL1R0
C1436	CHIP CERAMIC CAP.(1608) B K 0.01μF/50V	CHD1JK30B103
C1437	ELECTROLYTIC CAP. 22μF/16V M H7	CE1CMAVSL220
C1438	CHIP CERAMIC CAP. F Z 1μF/10V	CHD1AZ30F105
C1439	CHIP CERAMIC CAP.(1608) B K 0.01μF/50V	CHD1JK30B103
C1440	CHIP CERAMIC CAP. F Z 0.022μF/50V	CHD1JZ30F223
C1441	CHIP CERAMIC CAP. F Z 0.047μF/50V	CHD1JZ30F473
C1442	CHIP CERAMIC CAP. F Z 0.047μF/50V	CHD1JZ30F473
C1443	CHIP CERAMIC CAP. F Z 0.047μF/50V	CHD1JZ30F473
C1444	ELECTROLYTIC CAP. 22μF/16V M H7	CE1CMAVSL220
C1445	CHIP CERAMIC CAP.(1608) B K 0.01μF/50V	CHD1JK30B103
C1447	CHIP CERAMIC CAP.(1608) B K 0.01μF/50V	CHD1JK30B103
C1449	CHIP CERAMIC CAP.(1608) B K 0.01μF/50V	CHD1JK30B103
C1450	CHIP CERAMIC CAP.(1608) CH J 100pF/50V	CHD1JJ3CH101
C1452	CHIP CERAMIC CAP.(1608) B K 0.01μF/50V	CHD1JK30B103
C1461	ELECTROLYTIC CAP. 4.7μF/50V M H7	CE1JMAVSL4R7
C1463	CHIP CERAMIC CAP. CH J 820pF/25V	CHD1EJ3CH821
C1464	CHIP CERAMIC CAP.(1608) B K 2700pF/50V	CHD1JK30B272
C1465	ELECTROLYTIC CAP. 4.7μF/50V M H7	CE1JMAVSL4R7
C1466	CHIP CERAMIC CAP.(1608) B K 0.01μF/50V	CHD1JK30B103
C1467	CHIP CERAMIC CAP.(1608) B K 1000pF/50V	CHD1JK30B102
C1468	ELECTROLYTIC CAP. 33μF/16V M H7	CE1CMAVSL330
C1469	CHIP CERAMIC CAP.(1608) B K 0.015μF/50V	CHD1JK30B153
C1604▲	METALLIZED FILM CAP. 0.1μF/250V	CT2E104MS037
C1605▲	METALLIZED FILM CAP. 0.22μF/250V	CT2E224MS037
C1606	CERAMIC CAP. F Z 0.01μF/500V	CCD2JZP0F103
C1607	CERAMIC CAP. F Z 0.01μF/500V	CCD2JZP0F103
C1610	ELECTROLYTIC CAP. 470μF/200V	CA2D471NC013
C1611	CERAMIC CAP. BN 680pF/2KV	CCD3DKA0B681
C1612	FILM CAP.(P) 0.033μF/50V J	CMA1JJS00333
C1613	FILM CAP.(P) 0.0012μF/50V J	CMA1JJS00122
C1614	FILM CAP.(P) 0.082μF/50V J	CMA1JJS00823
C1615	CERAMIC CAP. BN 820pF/2KV	CCD3DKA0B821

Ref. No.	Description	Part No.
C1616	ELECTROLYTIC CAP. 100μF/160V M	CE2CMZPDL101
C1617▲	ELECTROLYTIC CAP. 470μF/35V M	CE1GMASDL471
C1618▲	ELECTROLYTIC CAP. 1000μF/16V M	CE1CMZPDL102
C1619	ELECTROLYTIC CAP. 1000μF/16V M	CE1CMZPDL102
C1620	ELECTROLYTIC CAP. 1000μF/16V M	CE1CMZPDL102
C1622	FILM CAP.(P) 0.0047μF/50V J	CMA1JJS00472
C1624	CHIP CERAMIC CAP.(1608) B K 0.01μF/50V	CHD1JK30B103
C1625	ELECTROLYTIC CAP. 0.47μF/50V M	CE1JMASDLR47
C1626▲	ELECTROLYTIC CAP. 10μF/50V M	CE1JMASDL100
C1630▲	SAFETY CAP 4700pF/250V KX	CA2E472MR050
C1633	ELECTROLYTIC CAP. 47μF/25V M	CE1EMASDL470
C1642	CHIP CERAMIC CAP.(1608) B K 1000pF/50V	CHD1JK30B102
C1643	ELECTROLYTIC CAP. 1000μF/6.3V M	CE0KMASDL102
C1650	CERAMIC CAP.(AX) B K 2200pF/50V	CA1J222TU011
C1661	ELECTROLYTIC CAP. 100μF/16V M	CE1CMASDL101
C1671	CERAMIC CAP. B K 2200pF/500V	CCD2JKS0B222
C1683	ELECTROLYTIC CAP. 220μF/6.3V M	CE0KMASDL221
C1685	ELECTROLYTIC CAP. 47μF/25V M	CE1EMASDL470
C1687	ELECTROLYTIC CAP. 22μF/50V M	CE1JMASDL220
C1688	ELECTROLYTIC CAP. 10μF/50V M	CE1JMASDL100
C1689	ELECTROLYTIC CAP. 47μF/25V M	CE1EMASDL470
C1701	CHIP CERAMIC CAP.(1608) F Z 0.1μF/50V	CHD1JZ30F104
C1722	CHIP CERAMIC CAP. F Z 1μF/10V	CHD1AZ30F105
C1732	CHIP CERAMIC CAP. F Z 1μF/10V	CHD1AZ30F105
C1740	CHIP CERAMIC CAP.(1608) F Z 0.1μF/50V	CHD1JZ30F104
C1747	ELECTROLYTIC CAP. 4.7μF/50V M H7	CE1JMAVSL4R7
C1748	CHIP CERAMIC CAP.(1608) B K 0.033μF/50V	CHD1JK30B333
C1749	CHIP CERAMIC CAP.(1608) F Z 0.1μF/50V	CHD1JZ30F104
C1751	ELECTROLYTIC CAP. 47μF/25V M	CE1EMASDL470
C1752	ELECTROLYTIC CAP. 1μF/50V M H7	CE1JMAVSL1R0
C1753	ELECTROLYTIC CAP. 10μF/25V M H7	CE1EMAVSL100
C1754	ELECTROLYTIC CAP. 1μF/50V M H7	CE1JMAVSL1R0
C1755	ELECTROLYTIC CAP. 22μF/16V M H7	CE1CMAVSL220
C1756	ELECTROLYTIC CAP. 10μF/25V M H7	CE1EMAVSL100
C1757	ELECTROLYTIC CAP. 4.7μF/50V M H7	CE1JMAVSL4R7
C1758	CHIP CERAMIC CAP.(1608) B K 0.01μF/50V	CHD1JK30B103
C1759	ELECTROLYTIC CAP. 22μF/16V M H7	CE1CMAVSL220
C1760	CHIP CERAMIC CAP.(1608) B K 4700pF/50V	CHD1JK30B472
C1761	CHIP CERAMIC CAP.(1608) B K 0.01μF/50V	CHD1JK30B103
C1762	CHIP CERAMIC CAP.(1608) B K 0.01μF/50V	CHD1JK30B103
C1763	CHIP CERAMIC CAP.(1608) B K 0.01μF/50V	CHD1JK30B103
C1764	ELECTROLYTIC CAP. 220μF/6.3V M H7	CE0KMAVSL221
C1765	CHIP CERAMIC CAP.(1608) B K 0.022μF/50V	CHD1JK30B223
C1766	ELECTROLYTIC CAP. 2.2μF/50V M H7	CE1JMAVSL2R2
C1767	CHIP CERAMIC CAP.(1608) B K 0.01μF/50V	CHD1JK30B103
C1768	ELECTROLYTIC CAP. 10μF/25V M H7	CE1EMAVSL100
C1769	ELECTROLYTIC CAP. 22μF/16V M H7	CE1CMAVSL220
C1770	CHIP CERAMIC CAP.(1608) B K 4700pF/50V	CHD1JK30B472
C1771	CHIP CERAMIC CAP.(1608) B K 0.01μF/50V	CHD1JK30B103
C1772	ELECTROLYTIC CAP. 4.7μF/50V M H7	CE1JMAVSL4R7
C1773	ELECTROLYTIC CAP. 10μF/25V M H7	CE1EMAVSL100
C1774	ELECTROLYTIC CAP. 1μF/50V M H7	CE1JMAVSL1R0
C1775	ELECTROLYTIC CAP. 1μF/50V M H7	CE1JMAVSL1R0
C1776	ELECTROLYTIC CAP. 1μF/50V M H7	CE1JMAVSL1R0
C1777	ELECTROLYTIC CAP. 1μF/50V M H7	CE1JMAVSL1R0
C1778	CERAMIC CAP.(AX) B K 0.01μF/50V	CA1J103TU011
C1779	ELECTROLYTIC CAP. 2.2μF/50V M H7	CE1JMAVSL2R2
C1780	ELECTROLYTIC CAP. 4.7μF/50V M H7	CE1JMAVSL4R7
C1781	ELECTROLYTIC CAP. 1μF/50V M H7	CE1JMAVSL1R0
C1782	ELECTROLYTIC CAP. 4.7μF/50V M H7	CE1JMAVSL4R7
C1783	ELECTROLYTIC CAP. 1μF/50V M H7	CE1JMAVSL1R0
C1784	CHIP CERAMIC CAP.(1608) F Z 0.1μF/50V	CHD1JZ30F104
C1786	ELECTROLYTIC CAP. 4.7μF/50V M H7	CE1JMAVSL4R7

Ref. No.	Description	Part No.
C1787	ELECTROLYTIC CAP. 22µF/16V M H7	CE1CMAVSL220
C1788	ELECTROLYTIC CAP. 4.7µF/50V M H7	CE1JMAVSL4R7
C1789	ELECTROLYTIC CAP. 22µF/16V M H7	CE1CMAVSL220
C1790	ELECTROLYTIC CAP. 4.7µF/50V M H7	CE1JMAVSL4R7
C1791	ELECTROLYTIC CAP. 4.7µF/50V M H7	CE1JMAVSL4R7
C1792	ELECTROLYTIC CAP. 4.7µF/50V M H7	CE1JMAVSL4R7
C1793	ELECTROLYTIC CAP. 4.7µF/50V M H7	CE1JMAVSL4R7
C1794	ELECTROLYTIC CAP. 10µF/50V M H7	CE1JMAVSL100
C1795	ELECTROLYTIC CAP. 4.7µF/50V M H7	CE1JMAVSL4R7
C1796	CHIP CERAMIC CAP. B K 2200pF/50V	CHD1JK30B222
C1797	ELECTROLYTIC CAP. 220µF/16V M	CE1CMASDL221
C1798	ELECTROLYTIC CAP. 100µF/6.3V H7	CE0KMAVSL101
C1801	ELECTROLYTIC CAP. 220µF/16V M	CE1CMASDL221
C1802	ELECTROLYTIC CAP. 470µF/16V M	CE1CMASDL471
C1807▲	ELECTROLYTIC CAP. 220µF/16V M	CE1CMASDL221
C1810	CHIP CERAMIC CAP. B K 680pF/50V	CHD1JK30B681
C1811	ELECTROLYTIC CAP. 0.47µF/50V M H7	CE1JMAVSLR47
C1812	CHIP CERAMIC CAP. B K 680pF/50V	CHD1JK30B681
C1813	ELECTROLYTIC CAP. 0.47µF/50V M	CE1JMASDLR47
C1814	ELECTROLYTIC CAP. 2.2µF/50V M H7	CE1JMAVSL2R2
C1815	ELECTROLYTIC CAP. 100µF/16V M	CE1CMASDL101
C1818	ELECTROLYTIC CAP. 10µF/16V M H7	CE1CMAVSL100
C1819	ELECTROLYTIC CAP. 10µF/16V M	CE1CMASDL100
C1821	ELECTROLYTIC CAP. 470µF/16V M	CE1CMASDL471
C1870	ELECTROLYTIC CAP. 47µF/6.3V M H7	CE0KMAVSL470
C1871	ELECTROLYTIC CAP. 100µF/16V M H7	CE1CMAVSL101
C1872	CERAMIC CAP. B K 470pF/100V	CCD2AKS0B471
C1873	FILM CAP.(P) 0.018µF/100V J	CMA2AJS00183
CONNECTORS		
CN1301	BOARD CONNECTOR 19P(PB FREE) 127301119K2	JCTWA19TG004
CN1302	242 SERIES CONNECTOR 224202105W1	J322C05TG001
CN1601	CONNECTOR BASE, 2P TV-50P-02-V3	J3TVCO2TG002
CN1602	BOARD CONNECTOR 19P(PB FREE) 127301119K2	JCTWA19TG004
CN1802	STRAIGHT CONNECTOR BASE 00 8283 0212 00 000	J383C02UG002
CN1803	TWG CONNECTOR 07P TWG-P07P-A1	J3TWA07TG001
DIODES		
D1204	LED LTL-4214M1	NPQZLTL4214M
D1216	LED LAMP 333GT/F45-50	NPWZ3GT/F4550
D1217	LED LTL-4214M1	NPQZLTL4214M
D1224	LED SIR-563ST3F P	QPQPS1R563ST
D1229	ZENER DIODE MTZJT-7715B	QDTB00MTZJ15
D1230	ZENER DIODE MTZJT-7715B	QDTB00MTZJ15
D1231	ZENER DIODE MTZJT-7718A	QDTA00MTZJ18
D1232	ZENER DIODE MTZJT-776.2B	QDTB0MTZJ6R2
D1234	SWITCHING DIODE 1SS133(T-77)	QDTZ001SS133
D1237	ZENER DIODE MTZJT-776.2B	QDTB0MTZJ6R2
D1302	SWITCHING DIODE 1SS133(T-77)	QDTZ001SS133
D1303	SWITCHING DIODE 1SS133(T-77)	QDTZ001SS133
D1304	SWITCHING DIODE 1SS133(T-77)	QDTZ001SS133
D1305	SWITCHING DIODE 1SS133(T-77)	QDTZ001SS133
D1311	SWITCHING DIODE 1SS133(T-77)	QDTZ001SS133
D1318	SWITCHING DIODE 1SS133(T-77)	QDTZ001SS133
D1350	SWITCHING DIODE 1SS133(T-77)	QDTZ001SS133
D1351	SWITCHING DIODE 1SS133(T-77)	QDTZ001SS133
D1353	ZENER DIODE MTZJT-779.1B	QDTB0MTZJ9R1
D1419	SWITCHING DIODE 1SS133(T-77)	QDTZ001SS133
D1420	SWITCHING DIODE 1SS133(T-77)	QDTZ001SS133
D1603▲	DIODE 1N5406	NDLZ001N5406
D1604▲	DIODE 1N5406	NDLZ001N5406
D1605▲	DIODE 1N5406	NDLZ001N5406

Ref. No.	Description	Part No.
D1606▲	DIODE 1N5406	NDLZ001N5406
D1607▲	ZENER DIODE MTZJT-7724C	QDTC00MTZJ24
D1609▲	SWITCHING DIODE 1SS133(T-77)	QDTZ001SS133
D1610	ZENER DIODE MTZJT-775.6B	QDTB0MTZJ5R6
D1611	SWITCHING DIODE 1SS133(T-77)	QDTZ001SS133
D1613▲	RECOVERY DIODE ERC18-04	QDZZ0ERC1804
D1614▲	DIODE FR104-B	NDLZ000FR104
D1615	RECTIFIER DIODE 1N4005	NDQZ001N4005
D1616▲	FAST RECOVERY DIODE FR202	NDWZ000FR202
D1617▲	FAST RECOVERY DIODE FR202	NDWZ000FR202
D1618▲	SCHOTTKY BARRIER DIODE ERA81-004Q	QDLZRA81004Q
D1619▲	DIODE FR104-B	NDLZ000FR104
D1620▲	ZENER DIODE MTZJT-776.8B	QDTB0MTZJ6R8
D1621	SWITCHING DIODE 1SS133(T-77)	QDTZ001SS133
D1622▲	SWITCHING DIODE 1SS133(T-77)	QDTZ001SS133
D1623	SWITCHING DIODE 1SS133(T-77)	QDTZ001SS133
D1626	ZENER DIODE MTZJT-7736A	QDTA00MTZJ36
D1627	ZENER DIODE MTZJT-7718C	QDTC00MTZJ18
D1628▲	SWITCHING DIODE 1SS133(T-77)	QDTZ001SS133
D1634	ZENER DIODE MTZJT-778.2B	QDTB0MTZJ8R2
D1635	SWITCHING DIODE 1SS133(T-77)	QDTZ001SS133
D1636	SWITCHING DIODE 1SS133(T-77)	QDTZ001SS133
D1640▲	DIODE 1ZC36	QDQZ0001ZC36
D1641▲	ZENER DIODE MTZJT-7739B	QDTB00MTZJ39
D1645▲	SCHOTTKY BARRIER DIODE ERB81-004	AERB81004***
D1657	SWITCHING DIODE 1SS133(T-77)	QDTZ001SS133
D1660▲	SWITCHING DIODE 1SS133(T-77)	QDTZ001SS133
D1663	ZENER DIODE MTZJT-776.8A	QDTA0MTZJ6R8
D1680▲	SWITCHING DIODE 1SS133(T-77)	QDTZ001SS133
D1682	SWITCHING DIODE 1SS133(T-77)	QDTZ001SS133
D1683	SWITCHING DIODE 1SS133(T-77)	QDTZ001SS133
D1684	SWITCHING DIODE 1SS133(T-77)	QDTZ001SS133
D1685▲	SWITCHING DIODE 1SS133(T-77)	QDTZ001SS133
D1687▲	SWITCHING DIODE 1SS133(T-77)	QDTZ001SS133
D1688▲	SWITCHING DIODE 1SS133(T-77)	QDTZ001SS133
D1691	SWITCHING DIODE 1SS133(T-77)	QDTZ001SS133
D1692	SWITCHING DIODE 1SS133(T-77)	QDTZ001SS133
D1811	SWITCHING DIODE 1SS133(T-77)	QDTZ001SS133
D1812	SWITCHING DIODE 1SS133(T-77)	QDTZ001SS133
D1813	SWITCHING DIODE 1SS133(T-77)	QDTZ001SS133
ICS		
IC1001	IC:VIF/SIF M61116FP TF0G	QSZBA0SHT034
IC1201▲	MICRO COMPUTER M3776AMCH-BA2GP	QSZAA0RHT062
IC1202	IC:MEMORY BR24C02F-W	QSMBAA0SRM003
IC1301▲	VCD IC M61275FP-TF3H	QSZAD0RMB133
IC1401	IC:Y/C/A LA71205M-MPB-E	QSZBA0RSY037
IC1601▲	PHOTOCOUPLER LTV-817C-F	NPECOLTV817F
IC1682▲	VOLTAGE REGULATOR KIA7805API	NSBBA0SJY011
IC1701	IC:HIFI LA72670M-A-MPB-E	QSZBA0RSY034
IC1803	IC AN17812A	QSZBA0SMS017
COILS		
L1001	CHOKE COIL 47µH-K	LLBD00PKV007
L1031	INDUCTOR 10µH-J-26T	LLAXJATTU100
L1032	INDUCTOR 100µH-J-26T	LLAXJATTU101
L1033	INDUCTOR 150µH-J-26T	LLAXJATTU151
L1202	INDUCTOR 0.10µH-K-26T	LLAXKATTUR10
L1203	PCB JUMPER D0.6-P5.0	JW5.0T
L1211	CHOKE COIL 47µH-K	LLBD00PKV007
L1302	PCB JUMPER D0.6-P5.0	JW5.0T
L1402	INDUCTOR 22µH-J-26T	LLAXJATTU220
L1403	CHOKE COIL 47µH-K	LLBD00PKV007
L1404	CHOKE COIL 47µH-K	LLBD00PKV007

Ref. No.	Description	Part No.
L1405	INDUCTOR 47μH-J-26T	LLAXJATTU470
L1601▲	LINE FILTER 2.7MH ELF15N013A	LLBG00ZMS037
L1751	PCB JUMPER D0.6-P5.0	JW5.0T
L1752	PCB JUMPER D0.6-P5.0	JW5.0T
L1871	PCB JUMPER D0.6-P5.0	JW5.0T
L1872	INDUCTOR 47μH-K-5FT	LLARKBSTU470
TRANSISTORS		
Q1205	TRANSISTOR 2SC2785(F)	QQSF02SC2785
Q1206	PHOTO TRANSISTOR MID-32A22F	NPWZ1D32A22F
Q1221	RES. BUILT-IN TRANSISTOR KRA103M	NQSZ0KRA103M
Q1350	TRANSISTOR 2SC1627Y-TPE2	QQSY02SC1627
Q1401	TRANSISTOR 2SA1175(F)	QQSF02SA1175
Q1402	TRANSISTOR 2SA1175(F)	QQSF02SA1175
Q1403	TRANSISTOR 2SA1175(F)	QQSF02SA1175
Q1404	TRANSISTOR 2SC2785(F)	QQSF02SC2785
Q1601▲	MOS FET 2SK3563	QFWZ02SK3563
Q1602▲	TRANSISTOR 2SC2120-O-TPE2	QQS002SC2120
Q1604▲	TRANSISTOR 2SC2785(F)	QQSF02SC2785
Q1605	TRANSISTOR 2SC2785(F)	QQSF02SC2785
Q1606▲	TRANSISTOR 2SA950(O)	Q2SA9500TPE2
Q1607▲	TRANSISTOR 2SC2785(F)	QQSF02SC2785
Q1609	TRANSISTOR 2SC2120-O-TPE2	QQS002SC2120
Q1613	TRANSISTOR KTC3199(GR)	NQS10KTC3199
Q1614	TRANSISTOR KTC3199(GR)	NQS10KTC3199
Q1681▲	TRANSISTOR 2SC2120-O-TPE2	QQS002SC2120
Q1682▲	TRANSISTOR 2SC2120-O-TPE2	QQS002SC2120
Q1683▲	TRANSISTOR 2SC2120-O-TPE2	QQS002SC2120
Q1688▲	TRANSISTOR 2SC2120-O-TPE2	QQS002SC2120
Q1701	TRANSISTOR 2SC2785(F)	QQSF02SC2785
Q1871	TRANSISTOR 2SA1175(F)	QQSF02SA1175
Q1872	TRANSISTOR 2SC2120-O-TPE2	QQS002SC2120
Q1873	TRANSISTOR 2SC3331(T)	QSC3331TNPAA
Q1874	TRANSISTOR 2SC3331(T)	QSC3331TNPAA
Q1875	RES. BUILT-IN TRANSISTOR KRA103M	NQSZ0KRA103M
RESISTORS		
R1002	CHIP RES.(1608) 1/10W J 100 Ω	RRXAJR5Z0101
R1003	CHIP RES.(1608) 1/10W J 100 Ω	RRXAJR5Z0101
R1032	CHIP RES.(1608) 1/10W J 100 Ω	RRXAJR5Z0101
R1033	CHIP RES.(1608) 1/10W J 390k Ω	RRXAJR5Z0394
R1034	CHIP RES.(1608) 1/10W J 1.8k Ω	RRXAJR5Z0182
R1037	CHIP RES.(1608) 1/10W J 180 Ω	RRXAJR5Z0181
R1038	CHIP RES.(1608) 1/10W J 1k Ω	RRXAJR5Z0102
R1039	CARBON RES. 1/4W J 1k Ω	RCX4JATZ0102
R1040	CHIP RES.(1608) 1/10W J 2.2k Ω	RRXAJR5Z0222
R1041	CARBON RES. 1/4W J 15k Ω	RCX4JATZ0153
R1042	CHIP RES.(1608) 1/10W J 15k Ω	RRXAJR5Z0153
R1043	PCB JUMPER D0.6-P5.0	JW5.0T
R1049	CHIP RES.(1608) 1/10W 0 Ω	RRXAZR5Z0000
R1050	CHIP RES.(1608) 1/10W 0 Ω	RRXAZR5Z0000
R1110	CHIP RES.(1608) 1/10W J 4.7k Ω	RRXAJR5Z0472
R1111	CHIP RES.(1608) 1/10W J 4.7k Ω	RRXAJR5Z0472
R1112	CHIP RES.(1608) 1/10W J 1.5k Ω	RRXAJR5Z0152
R1113	CHIP RES.(1608) 1/10W J 1.5k Ω	RRXAJR5Z0152
R1159	CHIP RES.(1608) 1/10W J 22k Ω	RRXAJR5Z0223
R1160	CHIP RES.(1608) 1/10W J 10k Ω	RRXAJR5Z0103
R1163	CHIP RES.(1608) 1/10W J 1.8k Ω	RRXAJR5Z0182
R1164	CHIP RES.(1608) 1/10W J 1.8k Ω	RRXAJR5Z0182
R1200	CHIP RES.(1608) 1/10W J 1k Ω	RRXAJR5Z0102
R1201	CARBON RES. 1/4W G 4.7k Ω	RCX4GATZ0472
R1202	CHIP RES. 1/16W G 22k Ω	RRXAGR5Z0223
R1203	CHIP RES. 1/16W G 470 Ω	RRXAGR5Z0471
R1204	CHIP RES. 1/16W G 1.5k Ω	RRXAGR5Z0152

Ref. No.	Description	Part No.
R1205	CHIP RES. 1/16W G 3.6k Ω	RRXAGR5Z0362
R1206	CHIP RES. 1/16W G 10k Ω	RRXAGR5Z0103
R1208▲	CHIP RES.(1608) 1/10W J 100k Ω	RRXAJR5Z0104
R1209	CHIP RES.(1608) 1/10W J 100 Ω	RRXAJR5Z0101
R1210	CHIP RES. 1/16W G 15k Ω	RRXAGR5Z0153
R1211	CHIP RES. 1/16W G 6.8k Ω	RRXAGR5Z0682
R1212	CARBON RES. 1/4W G 4.7k Ω	RCX4GATZ0472
R1213	CARBON RES. 1/4W J 10k Ω	RCX4JATZ0103
R1214	CARBON RES. 1/4W J 10k Ω	RCX4JATZ0103
R1215	CHIP RES. 1/16W G 1.5k Ω	RRXAGR5Z0152
R1216	CHIP RES. 1/16W G 1.5k Ω	RRXAGR5Z0152
R1217	CARBON RES. 1/4W G 2.2k Ω	RCX4GATZ0222
R1218	CHIP RES. 1/16W G 2.7k Ω	RRXAGR5Z0272
R1219	CHIP RES.(1608) 1/10W J 1k Ω	RRXAJR5Z0102
R1220	CARBON RES. 1/4W J 390k Ω	RCX4JATZ0394
R1221	CARBON RES. 1/4W J 1k Ω	RCX4JATZ0102
R1222	CHIP RES.(1608) 1/10W J 390k Ω	RRXAJR5Z0394
R1223	CHIP RES.(1608) 1/10W J 560 Ω	RRXAJR5Z0561
R1224	CARBON RES. 1/4W J 680 Ω	RCX4JATZ0681
R1225	CARBON RES. 1/4W J 100 Ω	RCX4JATZ0101
R1226	PCB JUMPER D0.6-P5.0	JW5.0T
R1227	CARBON RES. 1/4W J 270 Ω	RCX4JATZ0271
R1229	CARBON RES. 1/4W J 680 Ω	RCX4JATZ0681
R1231	CHIP RES.(1608) 1/10W J 100k Ω	RRXAJR5Z0104
R1232	CARBON RES. 1/4W J 6.8k Ω	RCX4JATZ0682
R1233	CHIP RES.(1608) 1/10W J 2.2k Ω	RRXAJR5Z0222
R1234	CHIP RES.(1608) 1/10W J 1.2k Ω	RRXAJR5Z0122
R1235	CARBON RES. 1/4W J 47 Ω	RCX4JATZ0470
R1236	CHIP RES.(1608) 1/10W J 100k Ω	RRXAJR5Z0104
R1237	CARBON RES. 1/4W J 1k Ω	RCX4JATZ0102
R1238	CHIP RES.(1608) 1/10W J 470k Ω	RRXAJR5Z0474
R1239	CHIP RES.(1608) 1/10W J 1k Ω	RRXAJR5Z0102
R1240	PCB JUMPER D0.6-P5.0	JW5.0T
R1241	CHIP RES.(1608) 1/10W J 4.7k Ω	RRXAJR5Z0472
R1243	CHIP RES.(1608) 1/10W J 1k Ω	RRXAJR5Z0102
R1244	CHIP RES.(1608) 1/10W J 1M Ω	RRXAJR5Z0105
R1245	CHIP RES.(1608) 1/10W J 470 Ω	RRXAJR5Z0471
R1246	CHIP RES.(1608) 1/10W J 4.7k Ω	RRXAJR5Z0472
R1247	CHIP RES.(1608) 1/10W J 820 Ω	RRXAJR5Z0821
R1248	CHIP RES.(1608) 1/10W J 470 Ω	RRXAJR5Z0471
R1249	CHIP RES.(1608) 1/10W J 3.3k Ω	RRXAJR5Z0332
R1250	CHIP RES.(1608) 1/10W J 1.5k Ω	RRXAJR5Z0152
R1251	CHIP RES.(1608) 1/10W J 3.3k Ω	RRXAJR5Z0332
R1252	CHIP RES.(1608) 1/10W J 1.5k Ω	RRXAJR5Z0152
R1253	CHIP RES.(1608) 1/10W J 3.3k Ω	RRXAJR5Z0332
R1254	CHIP RES.(1608) 1/10W J 1.5k Ω	RRXAJR5Z0152
R1255	CHIP RES.(1608) 1/10W J 100 Ω	RRXAJR5Z0101
R1256	CHIP RES.(1608) 1/10W J 6.8k Ω	RRXAJR5Z0682
R1257	CHIP RES.(1608) 1/10W J 100 Ω	RRXAJR5Z0101
R1258	CHIP RES.(1608) 1/10W J 100 Ω	RRXAJR5Z0101
R1259	CARBON RES. 1/4W J 1.2k Ω	RCX4JATZ0122
R1260	CHIP RES.(1608) 1/10W J 100 Ω	RRXAJR5Z0101
R1261	METAL OXIDE FILM RES. 1W J 1.2 Ω	RN011R2ZU001
R1262	CARBON RES. 1/4W J 680 Ω	RCX4JATZ0681
R1263	CHIP RES.(1608) 1/10W J 39k Ω	RRXAJR5Z0393
R1267	CARBON RES. 1/4W J 82k Ω	RCX4JATZ0823
R1268	CHIP RES.(1608) 1/10W J 10k Ω	RRXAJR5Z0103
R1269	PCB JUMPER D0.6-P5.0	JW5.0T
R1270	CHIP RES.(1608) 1/10W J 100k Ω	RRXAJR5Z0104
R1272	PCB JUMPER D0.6-P5.0	JW5.0T
R1273	CHIP RES.(1608) 1/10W J 1.8k Ω	RRXAJR5Z0182
R1274	CHIP RES.(1608) 1/10W J 1.5k Ω	RRXAJR5Z0152
R1275	CHIP RES.(1608) 1/10W J 200 Ω	RRXAJR5Z0201

Ref. No.	Description	Part No.
R1277	CHIP RES.(1608) 1/10W J 1k Ω	RRXAJR5Z0102
R1280	CHIP RES.(1608) 1/10W J 1k Ω	RRXAJR5Z0102
R1283	CHIP RES.(1608) 1/10W J 100k Ω	RRXAJR5Z0104
R1284	CARBON RES. 1/4W J 220k Ω	RCX4JATZ0224
R1285	CARBON RES. 1/4W J 5.6k Ω	RCX4JATZ0562
R1286	CARBON RES. 1/4W J 5.6k Ω	RCX4JATZ0562
R1287	CHIP RES.(1608) 1/10W J 1k Ω	RRXAJR5Z0102
R1288	CHIP RES.(1608) 1/10W J 47k Ω	RRXAJR5Z0473
R1289	CHIP RES.(1608) 1/10W 0 Ω	RRXAZR5Z0000
R1290	CHIP RES.(1608) 1/10W J 100 Ω	RRXAJR5Z0101
R1291	PCB JUMPER D0.6-P5.0	JW5.0T
R1292	PCB JUMPER D0.6-P5.0	JW5.0T
R1294	PCB JUMPER D0.6-P5.0	JW5.0T
R1298	CHIP RES.(1608) 1/10W J 1k Ω	RRXAJR5Z0102
R1299	CARBON RES. 1/4W J 10k Ω	RCX4JATZ0103
R1301	CHIP RES.(1608) 1/10W J 330 Ω	RRXAJR5Z0331
R1303	CHIP RES.(1608) 1/10W J 330 Ω	RRXAJR5Z0331
R1305	CHIP RES.(1608) 1/10W J 330 Ω	RRXAJR5Z0331
R1308	CARBON RES. 1/4W J 120k Ω	RCX4JATZ0124
R1310	CARBON RES. 1/4W J 180k Ω	RCX4JATZ0184
R1311	CHIP RES.(1608) 1/10W J 12k Ω	RRXAJR5Z0123
R1312	CHIP RES.(1608) 1/10W J 100 Ω	RRXAJR5Z0101
R1313	CHIP RES.(1608) 1/10W J 200 Ω	RRXAJR5Z0201
R1314	CHIP RES.(1608) 1/10W J 100 Ω	RRXAJR5Z0101
R1315	CHIP RES.(1608) 1/10W J 100 Ω	RRXAJR5Z0101
R1316	CHIP RES.(1608) 1/10W J 5.6k Ω	RRXAJR5Z0562
R1317	CHIP RES.(1608) 1/10W J 4.7M Ω	RRXAJR5Z0475
R1320	CHIP RES.(1608) 1/10W J 470k Ω	RRXAJR5Z0474
R1329	CARBON RES. 1/4W J 15k Ω	RCX4JATZ0153
R1333	CHIP RES.(1608) 1/10W J 100 Ω	RRXAJR5Z0101
R1334	CHIP RES.(1608) 1/10W J 1k Ω	RRXAJR5Z0102
R1335	CHIP RES.(1608) 1/10W J 5.6k Ω	RRXAJR5Z0562
R1336	CHIP RES.(1608) 1/10W J 5.6k Ω	RRXAJR5Z0562
R1337	CARBON RES. 1/4W J 470 Ω	RCX4JATZ0471
R1340	CARBON RES. 1/4W J 1k Ω	RCX4JATZ0102
R1350	CARBON RES. 1/4W J 470 Ω	RCX4JATZ0471
R1351	CARBON RES. 1/4W J 1k Ω	RCX4JATZ0102
R1352	CARBON RES. 1/4W J 33 Ω	RCX4JATZ0330
R1355	CARBON RES. 1/4W J 160 Ω	RCX4JATZ0161
R1356	CARBON RES. 1/4W J 160 Ω	RCX4JATZ0161
R1405	CARBON RES. 1/4W J 10k Ω	RCX4JATZ0103
R1406	CHIP RES.(1608) 1/10W J 10k Ω	RRXAJR5Z0103
R1407	CHIP RES.(1608) 1/10W J 18k Ω	RRXAJR5Z0183
R1408	CHIP RES.(1608) 1/10W J 18k Ω	RRXAJR5Z0183
R1409	CHIP RES.(1608) 1/10W J 6.8k Ω	RRXAJR5Z0682
R1410	CHIP RES.(1608) 1/10W J 10k Ω	RRXAJR5Z0103
R1411	CHIP RES.(1608) 1/10W 0 Ω	RRXAZR5Z0000
R1412	CHIP RES.(1608) 1/10W J 1k Ω	RRXAJR5Z0102
R1413	CHIP RES.(1608) 1/10W J 22k Ω	RRXAJR5Z0223
R1414	CHIP RES.(1608) 1/10W J 47k Ω	RRXAJR5Z0473
R1415	CHIP RES.(1608) 1/10W J 1.2k Ω	RRXAJR5Z0122
R1416	CHIP RES.(1608) 1/10W J 330k Ω	RRXAJR5Z0334
R1417	CARBON RES. 1/4W J 220 Ω	RCX4JATZ0221
R1418	CHIP RES.(1608) 1/10W J 330 Ω	RRXAJR5Z0331
R1419	CARBON RES. 1/4W J 330 Ω	RCX4JATZ0331
R1420	CHIP RES.(1608) 1/10W J 12k Ω	RRXAJR5Z0123
R1421	CHIP RES.(1608) 1/10W J 8.2k Ω	RRXAJR5Z0822
R1422	CHIP RES.(1608) 1/10W J 270 Ω	RRXAJR5Z0271
R1424	CHIP RES.(1608) 1/10W J 100k Ω	RRXAJR5Z0104
R1425	CHIP RES.(1608) 1/10W J 82k Ω	RRXAJR5Z0823
R1426	CHIP RES.(1608) 1/10W J 2.2k Ω	RRXAJR5Z0222
R1427	CHIP RES.(1608) 1/10W J 820 Ω	RRXAJR5Z0821
R1428	CHIP RES.(1608) 1/10W J 680k Ω	RRXAJR5Z0684

Ref. No.	Description	Part No.
R1429	CHIP RES.(1608) 1/10W J 1.2k Ω	RRXAJR5Z0122
R1430	CHIP RES.(1608) 1/10W J 1k Ω	RRXAJR5Z0102
R1431	CHIP RES.(1608) 1/10W J 8.2k Ω	RRXAJR5Z0822
R1432	CHIP RES.(1608) 1/10W J 1.2k Ω	RRXAJR5Z0122
R1433	CHIP RES.(1608) 1/10W J 4.7k Ω	RRXAJR5Z0472
R1436	CHIP RES.(1608) 1/10W J 2.2M Ω	RRXAJR5Z0225
R1602▲	CEMENT RES. 5W K 1.2 Ω	RW051R2DP005
R1603▲	METAL OXIDE FILM RES. 2W J 0.33 Ω	RN02R33ZU001
R1604	CARBON RES. 1/4W J 560k Ω	RCX4JATZ0564
R1605	CARBON RES. 1/4W J 560k Ω	RCX4JATZ0564
R1606	CARBON RES. 1/4W J 220 Ω	RCX4JATZ0221
R1607	CARBON RES. 1/4W J 220 Ω	RCX4JATZ0221
R1608	CARBON RES. 1/4W J 180k Ω	RCX4JATZ0184
R1609▲	CARBON RES. 1/4W J 1.5 Ω	RCX4JATZ01R5
R1610	CARBON RES. 1/4W J 1.2k Ω	RCX4JATZ0122
R1613	CARBON RES. 1/4W J 150 Ω	RCX4JATZ0151
R1614	CARBON RES. 1/4W J 1.2k Ω	RCX4JATZ0122
R1616	PCB JUMPER D0.6-P5.0	JW5.0T
R1617	CARBON RES. 1/4W J 180 Ω	RCX4JATZ0181
R1618	PCB JUMPER D0.6-P5.0	JW5.0T
R1619	METAL OXIDE FILM RES. 1W J 2.2k Ω	RN01222ZU001
R1620	METAL OXIDE FILM RES. 1W J 2.2k Ω	RN01222ZU001
R1621	METAL OXIDE FILM RES. 1W J 4.7k Ω	RN01472ZU001
R1622	PCB JUMPER D0.6-P5.0	JW5.0T
R1623	CARBON RES. 1/4W J 33k Ω	RCX4JATZ0333
R1624▲	CARBON RES. 1/4W J 47k Ω	RCX4JATZ0473
R1625▲	CARBON RES. 1/4W J 39k Ω	RCX4JATZ0393
R1629▲	CARBON RES. 1/4W J 13k Ω	RCX4JATZ0133
R1630	CARBON RES. 1/4W J 13k Ω	RCX4JATZ0133
R1631	CARBON RES. 1/4W J 12k Ω	RCX4JATZ0123
R1632▲	CARBON RES. 1/4W J 680 Ω	RCX4JATZ0681
R1633▲	CARBON RES. 1/4W J 5.6k Ω	RCX4JATZ0562
R1634	CARBON RES. 1/4W J 22k Ω	RCX4JATZ0223
R1635	CHIP RES.(1608) 1/10W J 10k Ω	RRXAJR5Z0103
R1636	METAL OXIDE FILM RES. 1W J 2.2k Ω	RN01222ZU001
R1637	PCB JUMPER D0.6-P5.0	JW5.0T
R1638	PCB JUMPER D0.6-P5.0	JW5.0T
R1639▲	CARBON RES. 1/2W J 1.2k Ω	RCX2JZQZ0122
R1640▲	CARBON RES. 1/4W J 56k Ω	RCX4JATZ0563
R1641	CARBON RES. 1/4W J 10k Ω	RCX4JATZ0103
R1642▲	CHIP RES.(1608) 1/10W J 6.8k Ω	RRXAJR5Z0682
R1644▲	CHIP RES.(1608) 1/10W J 47k Ω	RRXAJR5Z0473
R1645▲	CARBON RES. 1/4W J 220 Ω	RCX4JATZ0221
R1650	METAL OXIDE FILM RES. 1W J 4.7k Ω	RN01472ZU001
R1654▲	CARBON RES. 1/4W J 1.5 Ω	RCX4JATZ01R5
R1655▲	CARBON RES. 1/4W J 2.7k Ω	RCX4JATZ0272
R1662	CARBON RES. 1/4W J 560k Ω	RCX4JATZ0564
R1663	CARBON RES. 1/4W J 560k Ω	RCX4JATZ0564
R1664	CARBON RES. 1/4W J 100 Ω	RCX4JATZ0101
R1665	CARBON RES. 1/4W J 22 Ω	RCX4JATZ0220
R1666	CARBON RES. 1/4W J 680 Ω	RCX4JATZ0681
R1667	CARBON RES. 1/4W J 680 Ω	RCX4JATZ0681
R1673	CHIP RES.(1608) 1/10W 0 Ω	RRXAZR5Z0000
R1674	CHIP RES.(1608) 1/10W 0 Ω	RRXAZR5Z0000
R1675	CHIP RES.(1608) 1/10W J 330 Ω	RRXAJR5Z0331
R1676	CARBON RES. 1/4W J 100 Ω	RCX4JATZ0101
R1685	METAL RESISTOR 1W J 3.9 Ω	RN013R9ZU001
R1686	CARBON RES. 1/4W J 120 Ω	RCX4JATZ0121
R1688	CARBON RES. 1/2W J 12 Ω	RCX2JZQZ0120
R1689	CARBON RES. 1/4W J 4.7 Ω	RCX4JATZ04R7
R1691	CARBON RES. 1/4W J 5.6 Ω	RCX4JATZ05R6
R1692	CARBON RES. 1/2W J 12 Ω	RCX2JZQZ0120
R1693	CARBON RES. 1/2W J 18 Ω	RCX2JZQZ0180

Ref. No.	Description	Part No.
R1694	CARBON RES. 1/2W J 18 Ω	RCX2JZQZ0180
R1695	PCB JUMPER D0.6-P5.0	JW5.0T
R1701	CARBON RES. 1/4W J 75 Ω	RCX4JATZ0750
R1702	CHIP RES.(1608) 1/10W 0 Ω	RRXAZR5Z0000
R1703	PCB JUMPER D0.6-P5.0	JW5.0T
R1731	CHIP RES.(1608) 1/10W J 47k Ω	RRXAJR5Z0473
R1732	PCB JUMPER D0.6-P5.0	JW5.0T
R1734	CHIP RES.(1608) 1/10W J 47k Ω	RRXAJR5Z0473
R1735	PCB JUMPER D0.6-P5.0	JW5.0T
R1750	CHIP RES.(1608) 1/10W J 1k Ω	RRXAJR5Z0102
R1751	CHIP RES.(1608) 1/10W J 4.7k Ω	RRXAJR5Z0472
R1752	CHIP RES.(1608) 1/10W J 12k Ω	RRXAJR5Z0123
R1753	CHIP RES.(1608) 1/10W J 47k Ω	RRXAJR5Z0473
R1754	CHIP RES.(1608) 1/10W J 8.2k Ω	RRXAJR5Z0822
R1755	CHIP RES.(1608) 1/10W J 470 Ω	RRXAJR5Z0471
R1756	CHIP RES.(1608) 1/10W J 2.2k Ω	RRXAJR5Z0222
R1757	CHIP RES.(1608) 1/10W J 47k Ω	RRXAJR5Z0473
R1758	CHIP RES.(1608) 1/10W J 8.2k Ω	RRXAJR5Z0822
R1759	CHIP RES.(1608) 1/10W J 1k Ω	RRXAJR5Z0102
R1761	CARBON RES. 1/4W J 1k Ω	RCX4JATZ0102
R1764	CHIP RES.(1608) 1/10W J 22k Ω	RRXAJR5Z0223
R1766	PCB JUMPER D0.6-P5.0	JW5.0T
R1767	CARBON RES. 1/4W J 1k Ω	RCX4JATZ0102
R1769	CHIP RES.(1608) 1/10W J 4.7k Ω	RRXAJR5Z0472
R1770	CHIP RES.(1608) 1/10W 0 Ω	RRXAZR5Z0000
R1771	CHIP RES.(1608) 1/10W 0 Ω	RRXAZR5Z0000
R1772	CARBON RES. 1/4W J 47k Ω	RCX4JATZ0473
R1773	CHIP RES.(1608) 1/10W J 47k Ω	RRXAJR5Z0473
R1774	CHIP RES.(1608) 1/10W J 22k Ω	RRXAJR5Z0223
R1780	CHIP RES.(1608) 1/10W J 6.8k Ω	RRXAJR5Z0682
R1781	CHIP RES.(1608) 1/10W J 8.2k Ω	RRXAJR5Z0822
R1801▲	CARBON RES. 1/4W J 180 Ω	RCX4JATZ0181
R1802	CARBON RES. 1/4W J 180 Ω	RCX4JATZ0181
R1803▲	METAL OXIDE FILM RES. 1W J 12 Ω	RN01120ZU001
R1808▲	METAL OXIDE FILM RES. 1W J 12 Ω	RN01120ZU001
R1809	CHIP RES.(1608) 1/10W J 2.2k Ω	RRXAJR5Z0222
R1810	CHIP RES.(1608) 1/10W J 2.2k Ω	RRXAJR5Z0222
R1813	CARBON RES. 1/4W J 18k Ω	RCX4JATZ0183
R1814	CARBON RES. 1/4W J 18k Ω	RCX4JATZ0183
R1815	CARBON RES. 1/4W J 33k Ω	RCX4JATZ0333
R1816	CHIP RES.(1608) 1/10W J 33k Ω	RRXAJR5Z0333
R1871	CHIP RES.(1608) 1/10W J 1k Ω	RRXAJR5Z0102
R1872	CHIP RES.(1608) 1/10W J 22k Ω	RRXAJR5Z0223
R1873	CARBON RES. 1/4W J 18k Ω	RCX4JATZ0183
R1874	CARBON RES. 1/4W J 100 Ω	RCX4JATZ0101
R1875	CHIP RES.(1608) 1/10W J 2.2k Ω	RRXAJR5Z0222
R1876	CHIP RES.(1608) 1/10W J 2.2k Ω	RRXAJR5Z0222
R1877	CARBON RES. 1/4W J 820 Ω	RCX4JATZ0821
SWITCHES		
SW1201	TACT SWITCH SKQSAB	SST0101AL038
SW1202	TACT SWITCH SKQSAB	SST0101AL038
SW1203	TACT SWITCH SKQSAB	SST0101AL038
SW1206	TACT SWITCH SKQSAB	SST0101AL038
SW1207	TACT SWITCH SKQSAB	SST0101AL038
SW1208	TACT SWITCH SKQSAB	SST0101AL038
SW1209	TACT SWITCH SKQSAB	SST0101AL038
SW1210	TACT SWITCH SKQSAB	SST0101AL038
SW1211	LEAF SWITCH LSA-1142-2AU	SSC0101KB014
SW1212	ROTARY MODE SWITCH SSS-53MD	SSR0106KB003
MISCELLANEOUS		
BC1600	BEAD INDUCTORS FBR07HA121TB-00	LLBF00ZTU021
BC1601	PCB JUMPER D0.6-P5.0	JW5.0T

Ref. No.	Description	Part No.
BC1602	PCB JUMPER D0.6-P5.0	JW5.0T
BC1604	PCB JUMPER D0.6-P5.0	JW5.0T
BC1605	BEAD INDUCTORS FBA04HA600VB-00	LLBF00STU026
BC1606	BEAD INDUCTORS FBR07HA121TB-00	LLBF00ZTU021
BC1607	BEAD INDUCTORS FBA04HA600VB-00	LLBF00STU026
BC1608	PCB JUMPER D0.6-P5.0	JW5.0T
BC1609	PCB JUMPER D0.6-P5.0	JW5.0T
CF1032	CERAMIC FILTER SFSRA4M50CF00-B0	FBB455PMR004
CL1201	FMN CONNECTOR, TOP 12P 12FMN-BTRK	JCFNG12JG002
F1601▲	FUSE 4.00A/125V	PAGU20CAG402
FH1601	FUSE HOLDER MSF-015	XH01Z00LY001
FH1602	FUSE HOLDER MSF-015	XH01Z00LY001
JK1701	RCA JACK(YELLOW) MTJ-032-05B-20	JXRL010LY038
JK1702	RCA JACK(WHITE) MTJ-032-05B-22	JXRL010LY039
JK1703	RCA JACK(RED) MTJ-032-05A-21	JYRL010LY010
JK1801	MINI JACK HSJ2000-01-010	JYSL010HD002
JM1201	PCB JUMPER D0.6-P5.0	JW5.0T
JM1403	PCB JUMPER D0.6-P30.0	JW30.0T
JM1601	PCB JUMPER D0.6-P5.0	JW5.0T
JM1602	PCB JUMPER D0.6-P5.0	JW5.0T
PS1601▲	THERMISTOR ZPB45BL3R0A	QNBZ45BL3R0A
RS1201	REMOTE RECEIVER PIC-37042LU	USESJRSKK033
SA1601▲	SURGE ABSORBER 470V+-10PER	NVQZ10D471KB
SF1001	SAW FILTER SAFHM45M7VAJZ01B03	FBB456PMR012
SG1601▲	GAP. FNR-G3.10D	FAZ000LD6005
T1601▲	SWITCHING TRANS 4717	LTT00CPKT130
TB3	HEAD SHIELD (X5) T1000UA	OEM302062
TB7	LED HOLDER T1100UA	1EM420616
TB13	BUSH, LED(F) H3700UD	OVM409508
TB17	X5 MAIN HEATSINK PJI ASSEMBLY T1000UA	OEM409069A
TL6	SCREW, B-TIGHT D3X8 BIND HEAD+	GBMB3080
TP1001	PCB JUMPER D0.6-P12.5	JW12.5T
TP1002	PCB JUMPER D0.6-P15.0	JW15.0T
TP1202	PCB JUMPER D0.6-P17.5	JW17.5T
TP1301	PCB JUMPER D0.6-P5.0	JW5.0T
TP1302	PCB JUMPER D0.6-P5.0	JW5.0T
TP1303	PCB JUMPER D0.6-P5.0	JW5.0T
TP1401	PCB JUMPER D0.6-P10.0	JW10.0T
TP1402	PCB JUMPER D0.6-P26.5	JW26.5T
TP1671	PCB JUMPER D0.6-P11.0	JW11.0T
TP1672	PCB JUMPER D0.6-P8.5	JW8.5T
TP1673	PCB JUMPER D0.6-P8.5	JW8.5T
TP1701	PCB JUMPER D0.6-P8.0	JW8.0T
TP1702	PCB JUMPER D0.6-P5.0	JW5.0T
TP1703	PCB JUMPER D0.6-P19.0	JW19.0T
TU1001	TUNER UNIT TEFH9-001A	UTUNNTUAL042
VR1601▲	CARBON P.O.T. VZ067TL1 B103 PB(F)	VRCB103HH014
W1601▲	AC CORD PB8K9F9110A-057	WAC0172LW008
X1201	X'TAL 32.768kHz(20PPM)	FXC323LJNY01
X1202	X'TAL HC-49/U 10.6MHz	FXD106LLN001
X1301	X'TAL 3.579545 MHz	FXD355LLN003
X1401	X'TAL 3.579545MHz(20PPM)	FXC355LLN003

SENSOR CBA

Ref. No.	Description	Part No.
	SENSOR CBA Consists of the following:	1ESA10448
TRANSISTORS		
Q201	PHOTO TRANSISTOR MID-32A22F	NPWZ1D32A22F
Q202	PHOTO TRANSISTOR MID-32A22F	NPWZ1D32A22F

MPS CBA

Ref. No.	Description	Part No.
	MPS CBA Consists of the following:	1ESA10436
	SUB CBA (MPS-A)	-----
	CRT CBA (MPS-B)	-----
	FUNCTION CBA (MPS-C)	-----
	JUNCTION CBA	-----

SUB CBA

Ref. No.	Description	Part No.
	SUB CBA (MPS-A) Consists of the following:	-----
CAPACITORS		
C2531	METALLIZED FILM CAP. 0.27 μ F/200V J	CT2D274F7003
C2533▲	P.P. CAP 0.0082 μ F/1.6K J	CA3C822V0C11
C2552	MYLAR CAP. 0.22 μ F/50V J	CMA1JJS00224
C2553	ELECTROLYTIC CAP. 2.2 μ F/50V M LL	CE1JMASLL2R2
C2555	ELECTROLYTIC CAP. 47 μ F/35V M	CE1GMASDL470
C2556	ELECTROLYTIC CAP. 1000 μ F/25V M	CE1EMZPDL102
C2558	CERAMIC CAP.(AX) Y M 0.01 μ F/16V	CCA1GMT0Y103
C2559	ELECTROLYTIC CAP. 330 μ F/35V M	CE1GMASDL331
C2560	FILM CAP.(P) 0.01 μ F/50V J	CMA1JJS00103
C2561	ELECTROLYTIC CAP. 47 μ F/25V M	CE1EMASDL470
C2574▲	ELECTROLYTIC CAP. 4.7 μ F/250V M	CE2EMASDL4R7
C2577	FILM CAP.(P) 0.022 μ F/50V J	CMA1JJS00223
C2578	ELECTROLYTIC CAP. 47 μ F/35V M	CE1GMASDL470
C2583	ELECTROLYTIC CAP. 1 μ F/160V M	CE2CMASDL1R0
C2584▲	PCB JUMPER D0.6-P5.0	JW5.0T
C2586	ELECTROLYTIC CAP. 4.7 μ F/50V M	CE1JMASDL4R7
C2588	ELECTROLYTIC CAP. 47 μ F/50V M	CE1JMASDL470
C2590	ELECTROLYTIC CAP. 2.2 μ F/50V M	CE1JMASDL2R2
C2591▲	CERAMIC CAP.(AX) Y M 0.01 μ F/16V	CCA1GMT0Y103
C2592	ELECTROLYTIC CAP. 47 μ F/25V M	CE1EMASDL470
C2594	ELECTROLYTIC CAP. 47 μ F/160V M W/F	CE2CMZNDL470
C2595▲	CERAMIC CAP. BN 1200pF/2KV	CCD3DKA0B122
C2601	CERAMIC CAP.(AX) F Z 0.1 μ F/50V	CCA1JZTFZ104
C2604	ELECTROLYTIC CAP. 1000 μ F/6.3V M	CE0KMASDL102
C2610	ELECTROLYTIC CAP. 47 μ F/25V M	CE1EMASDL470
C2616	ELECTROLYTIC CAP. 100 μ F/6.3V M	CE0KMASDL101
C2618	CERAMIC CAP.(AX) B K 1000pF/50V	CCA1JKT0B102
C2625	ELECTROLYTIC CAP. 47 μ F/25V M	CE1EMASDL470
C2627	ELECTROLYTIC CAP. 470 μ F/6.3V M	CE0KMASDL471
C2629	ELECTROLYTIC CAP. 220 μ F/6.3V M	CE0KMASDL221
C2630	ELECTROLYTIC CAP. 470 μ F/16V M	CE1CMASDL471
C2645	CERAMIC CAP.(AX) Y M 0.01 μ F/16V	CCA1CMT0Y103
C2647	ELECTROLYTIC CAP. 100 μ F/10V M	CE1AMASDL101
C2654	CERAMIC CAP.(AX) Y M 0.01 μ F/16V	CCA1CMT0Y103
C2670	ELECTROLYTIC CAP. 470 μ F/6.3V M	CE0KMASDL471
CONNECTORS		
CN2502	TWG CONNECTOR 19P TWG-P19P-A1	J3TWA19TG001
CN2503	TWG CONNECTOR 19P TWG-P19P-A1	J3TWA19TG001
CN2571	CONNECTOR BASE, 5P TV-50P-05-V3	J3TVC05TG002
DIODES		
D2552	DIODE FR104-B	NDLZ000FR104
D2571	RECTIFIER DIODE FR202-B/P	NDQZ000FR202
D2572▲	DIODE FR104-B	NDLZ000FR104
D2584	SWITCHING DIODE 1SS133(T-77)	QDTZ001SS133
D2585	ZENER DIODE MTZJT-775.1B	QDTB0MTZJ5R1
D2586	PCB JUMPER D0.6-P5.0	JW5.0T
D2591▲	ZENER DIODE MTZJT-7736B	QDTB00MTZJ36
D2595▲	ZENER DIODE MTZJT-7720C	QDTC00MTZJ20
D2596▲	SWITCHING DIODE 1SS133(T-77)	QDTZ001SS133

Ref. No.	Description	Part No.
D2597▲	SWITCHING DIODE 1SS133(T-77)	QDTZ001SS133
D2598▲	DIODE FR104-B	NDLZ000FR104
D2601	SWITCHING DIODE 1SS133(T-77)	QDTZ001SS133
D2602	SWITCHING DIODE 1SS133(T-77)	QDTZ001SS133
D2603	ZENER DIODE MTZJT-775.6C	QDTC0MTZJ5R6
D2613▲	RECTIFIER DIODE ERA15-02	AERA1502****
D2625	SWITCHING DIODE 1SS133(T-77)	QDTZ001SS133
D2627	ZENER DIODE MTZJT-773.9B	QDTB0MTZJ3R9
D2648	SWITCHING DIODE 1SS133(T-77)	QDTZ001SS133
D2649	SWITCHING DIODE 1SS133(T-77)	QDTZ001SS133
D2651	SWITCHING DIODE 1SS133(T-77)	QDTZ001SS133
D2661	SWITCHING DIODE 1SS133(T-77)	QDTZ001SS133
D2662	SWITCHING DIODE 1SS133(T-77)	QDTZ001SS133
ICs		
IC2551	VERTICAL OUTPUT IC LA78040A	QSBBA0SSY003
IC2602	VOLTAGE REGULATOR PQ070XF01SZH	QSZBA0SSH054
IC3603	IC:SHUNT REGULATOR KIA431-AT	NSZLA0TJY001
IC3604	IC:SHUNT REGULATOR KIA431-AT	NSZLA0TJY001
COILS		
L2505	CHOKE COIL 22 μ H-K	LLBD00PKV006
L2610	PCB JUMPER D0.6-P5.0	JW5.0T
L2613	INDUCTOR 10 μ H-K-5FT	LLARKBSTU100
L2621	PCB JUMPER D0.6-P5.0	JW5.0T
TRANSISTORS		
Q2571	TRANSISTOR TT2140LS-YB11	QQZZ00TT2140
Q2591▲	TRANSISTOR 2SC1627Y-TPE2	QQSY02SC1627
Q2592▲	TRANSISTOR 2SC2785(F)	QQSF02SC2785
Q2610	TRANSISTOR 2SA1175(F)	QQSF02SA1175
Q2611	TRANSISTOR KTC3199(GR)	NQS10KTC3199
Q2612	TRANSISTOR 2SC2785(F)	QQSF02SC2785
Q2615	TRANSISTOR 2SD400(F)	QQUF002SD400
Q2616	RES. BUILT-IN TRANSISTOR KRC103M	NQSZOKRC103M
Q2617	TRANSISTOR KTC3199(GR)	NQS10KTC3199
RESISTORS		
R2501	CARBON RES. 1/4W J 39k Ω	RCX4JATZ0393
R2504	CARBON RES. 1/4W J 15k Ω	RCX4JATZ0153
R2505	METAL OXIDE FILM RES. 2W J 1k Ω	RN02102ZU001
R2506	METAL OXIDE FILM RES. 2W J 1k Ω	RN02102ZU001
R2541	CARBON RES. 1/4W J 1k Ω	RCX4JATZ0102
R2542	CARBON RES. 1/4W J 1k Ω	RCX4JATZ0102
R2543	CARBON RES. 1/4W J 1k Ω	RCX4JATZ0102
R2550	CARBON RES. 1/4W J 1.5k Ω	RCX4JATZ0152
R2551	CARBON RES. 1/4W J 1.5k Ω	RCX4JATZ0152
R2552	CARBON RES. 1/4W J 1.5k Ω	RCX4JATZ0152
R2555	PCB JUMPER D0.6-P5.0	JW5.0T
R2556	CARBON RES. 1/4W J 1 Ω	RCX4JATZ01R0
R2557	CARBON RES. 1/4W J 470 Ω	RCX4JATZ0471
R2558	CARBON RES. 1/4W J 12k Ω	RCX4JATZ0123
R2559	PCB JUMPER D0.6-P5.0	JW5.0T
R2560	CARBON RES. 1/4W J 2.7k Ω	RCX4JATZ0272
R2561	CARBON RES. 1/4W J 3.9k Ω	RCX4JATZ0392
R2562	CARBON RES. 1/4W J 6.8 Ω	RCX4JATZ06R8
R2563	CARBON RES. 1/4W J 6.8 Ω	RCX4JATZ06R8
R2564	CARBON RES. 1/4W J 6.8 Ω	RCX4JATZ06R8
R2565▲	PCB JUMPER D0.6-P5.0	JW5.0T
R2566▲	CARBON RES. 1/4W J 1.5 Ω	RCX4JATZ01R5
R2567▲	CARBON RES. 1/4W J 1.5 Ω	RCX4JATZ01R5
R2568▲	CARBON RES. 1/4W J 1.8 Ω	RCX4JATZ01R8
R2571	CARBON RES. 1/4W J 1k Ω	RCX4JATZ0102
R2572	CARBON RES. 1/4W J 1k Ω	RCX4JATZ0102
R2573	CARBON RES. 1/4W J 1k Ω	RCX4JATZ0102
R2574	PCB JUMPER D0.6-P5.0	JW5.0T

Ref. No.	Description	Part No.
R2576	CARBON RES. 1/4W J 180 Ω	RCX4JATZ0181
R2577	CARBON RES. 1/4W J 180 Ω	RCX4JATZ0181
R2580▲	CARBON RES. 1/4W J 56 Ω	RCX4JATZ0560
R2581	CARBON RES. 1/4W J 470 Ω	RCX4JATZ0471
R2583▲	METAL RESISTER. 2W J 2.7 Ω	RN022R7ZU001
R2584	CARBON RES. 1/4W J 1k Ω	RCX4JATZ0102
R2585	CARBON RES. 1/4W J 6.8k Ω	RCX4JATZ0682
R2586	PCB JUMPER D0.6-P5.0	JW5.0T
R2587	CARBON RES. 1/4W J 100k Ω	RCX4JATZ0104
R2588	CARBON RES. 1/4W J 100k Ω	RCX4JATZ0104
R2589▲	CARBON RES. 1/4W J 56 Ω	RCX4JATZ0560
R2590	CARBON RES. 1/4W J 56 Ω	RCX4JATZ0560
R2591▲	CARBON RES. 1/4W J 22k Ω	RCX4JATZ0223
R2592	CARBON RES. 1/4W J 180k Ω	RCX4JATZ0184
R2593	CARBON RES. 1/4W J 68k Ω	RCX4JATZ0683
R2594	CARBON RES. 1/4W J 56k Ω	RCX4JATZ0563
R2598▲	CARBON RES. 1/4W J 22k Ω	RCX4JATZ0223
R2599▲	CARBON RES. 1/4W J 5.6k Ω	RCX4JATZ0562
R2613	CARBON RES. 1/4W J 1 Ω	RCX4JATZ01R0
R2617	CARBON RES. 1/4W J 47k Ω	RCX4JATZ0473
R2618	CARBON RES. 1/4W J 390 Ω	RCX4JATZ0391
R2638	PCB JUMPER D0.6-P5.0	JW5.0T
R2646	CARBON RES. 1/4W J 22k Ω	RCX4JATZ0223
R2647	CARBON RES. 1/4W J 22k Ω	RCX4JATZ0223
R2649	PCB JUMPER D0.6-P5.0	JW5.0T
R2650	CARBON RES. 1/4W J 2.2 Ω	RCX4JATZ02R2
R2651	CARBON RES. 1/4W J 47k Ω	RCX4JATZ0473
R2652	CARBON RES. 1/4W J 180 Ω	RCX4JATZ0181
R2653	CARBON RES. 1/4W J 33 Ω	RCX4JATZ0330
R2655	PCB JUMPER D0.6-P5.0	JW5.0T
R2656	CARBON RES. 1/4W J 22k Ω	RCX4JATZ0223
R2657	CARBON RES. 1/4W J 22k Ω	RCX4JATZ0223
R2659	CARBON RES. 1/4W J 820 Ω	RCX4JATZ0821
R2660	CARBON RES. 1/4W J 820 Ω	RCX4JATZ0821
R2669	PCB JUMPER D0.6-P5.0	JW5.0T
R2671	CARBON RES. 1/4W G 5.6k Ω	RCX4GATZ0562
R2672	CARBON RES. 1/4W G 15k Ω	RCX4GATZ0153
R2673	CARBON RES. 1/4W J 1k Ω	RCX4JATZ0102
R2675	CARBON RES. 1/4W J 1 Ω	RCX4JATZ01R0
R2676	METAL OXIDE FILM RES. 2W J 3.9 Ω	RN023R9ZU001
R2677	CARBON RES. 1/4W J 1 Ω	RCX4JATZ01R0
R2678	CARBON RES. 1/4W J 560 Ω	RCX4JATZ0561
R2684	CARBON RES. 1/4W G 220 Ω	RCX4GATZ0221
R2685	CARBON RES. 1/4W G 8.2k Ω	RCX4GATZ0822
R2686	CARBON RES. 1/4W G 4.7k Ω	RCX4GATZ0472
R2687	CARBON RES. 1/4W G 5.6k Ω	RCX4GATZ0562
R2688	CARBON RES. 1/4W G 15k Ω	RCX4GATZ0153
R2689	CARBON RES. 1/4W J 3.9k Ω	RCX4JATZ0392
R2691	CARBON RES. 1/4W J 2.2 Ω	RCX4JATZ02R2
R3506	PCB JUMPER D0.6-P5.0	JW5.0T
R3568▲	CARBON RES. 1/4W J 2.7 Ω	RCX4JATZ02R7
R3576	PCB JUMPER D0.6-P5.0	JW5.0T
R3580	PCB JUMPER D0.6-P5.0	JW5.0T
MISCELLANEOUS		
BC2501	BEAD INDUCTORS FBA04HA600VB-00	LLBF00STU026
BC2602	PCB JUMPER D0.6-P5.0	JW5.0T
BC2603	PCB JUMPER D0.6-P5.0	JW5.0T
BC2604	PCB JUMPER D0.6-P5.0	JW5.0T
BC2605	PCB JUMPER D0.6-P5.0	JW5.0T
CL2501	LEAD WIRE 3P 420MM	WX1T1000-001
CL2504	LEAD WIRE 5P 300MM	WX1T0100-003
DB2	X6 V-HEAT SINK PKA T1100UA	1EM420563

Ref. No.	Description	Part No.
DB5	X6 H-HEAT SINK PJZ T1100UA	1EM420564
DL2	SCREW, B-TIGHT D3X8 BIND HEAD+	GBMB3080
JK2601	RCA JACK MSP-241V-05 PBSN W/O	JXRLO10LY085
JS2601	PCB JUMPER D0.6-P5.0	JW5.0T
T2571▲	FLYBACK TRANSFORMER JF0501-3201A	LTF00CPXB040
T2572▲	HORIZONTAL DRIVE TRANS LP2-005	LTH00CPA5005
TP2501	PCB JUMPER D0.6-P10.0	JW10.0T
TP2502	PCB JUMPER D0.6-P5.0	JW5.0T
TP2503	PCB JUMPER D0.6-P5.0	JW5.0T
TP2504	PCB JUMPER D0.6-P5.0	JW5.0T
TP2505	PCB JUMPER D0.6-P5.0	JW5.0T

CRT CBA

Ref. No.	Description	Part No.
	CRT CBA (MPS-B) Consists of the following:	-----
CAPACITORS		
C2504	CERAMIC CAP.(AX) B J 390pF/50V	CCA1JUT0B391
C2505	CERAMIC CAP.(AX) B J 330pF/50V	CCA1JUT0B331
C2506	CERAMIC CAP.(AX) B J 330pF/50V	CCA1JUT0B331
C2508	ELECTROLYTIC CAP. 47μF/25V M	CE1EMASDL470
C2509	CERAMIC CAP. B K 1000pF/25KV	CCD3DKP0B102
C2510	ELECTROLYTIC CAP. 1μF/50V M	CE1JMASDL1R0
CONNECTOR		
CN2501	CONNECTOR PIN, 1P RT-01N-2.3A	1730688
DIODES		
D2501	SWITCHING DIODE 1SS133(T-77)	QDTZ001SS133
D2502	SWITCHING DIODE 1SS133(T-77)	QDTZ001SS133
D2503	SWITCHING DIODE 1SS133(T-77)	QDTZ001SS133
D2505	PCB JUMPER D0.6-P5.0	JW5.0T
COIL		
L2501	INDUCTOR 180μH-J-5FT	LLARJCSTU181
TRANSISTORS		
Q2501	TRANSISTOR 2SC2482 TPE6	QQSZ02SC2482
Q2502	TRANSISTOR 2SC2482 TPE6	QQSZ02SC2482
Q2503	TRANSISTOR 2SC2482 TPE6	QQSZ02SC2482
RESISTORS		
R2502	CARBON RES. 1/4W J 1.5k Ω	RCX4JATZ0152
R2503	CARBON RES. 1/4W J 1.5k Ω	RCX4JATZ0152
R2507	CARBON RES. 1/4W J 33 Ω	RCX4JATZ0330
R2508	CARBON RES. 1/4W J 33 Ω	RCX4JATZ0330
R2509	CARBON RES. 1/4W J 33 Ω	RCX4JATZ0330
R2510	CARBON RES. 1/4W J 5.6k Ω	RCX4JATZ0562
R2511	CARBON RES. 1/4W J 5.6k Ω	RCX4JATZ0562
R2512	CARBON RES. 1/4W J 5.6k Ω	RCX4JATZ0562
R2513	CARBON RES. 1/4W J 560 Ω	RCX4JATZ0561
R2514	CARBON RES. 1/4W J 560 Ω	RCX4JATZ0561
R2515	CARBON RES. 1/4W J 560 Ω	RCX4JATZ0561
R2516▲	METAL OXIDE FILM RES. 1W J 15k Ω	RN01153ZU001
R2517▲	METAL OXIDE FILM RES. 1W J 15k Ω	RN01153ZU001
R2518▲	METAL OXIDE FILM RES. 1W J 15k Ω	RN01153ZU001
R2519	CARBON RES. 1/4W J 1.5k Ω	RCX4JATZ0152
R2520	CARBON RES. 1/4W J 1.5k Ω	RCX4JATZ0152
R2521	CARBON RES. 1/4W J 1.5k Ω	RCX4JATZ0152
R2523	CARBON RES. 1/4W J 1.5k Ω	RCX4JATZ0152
MISCELLANEOUS		
JK2501▲	CRT SOCKET ISMS02S	JSCC220PK003

FUNCTION CBA

Ref. No.	Description	Part No.
	FUNCTION CBA (MPS-C) Consists of the following:	-----
CONNECTORS		
CN2401	BOARD CONNECTOR 07P(PB FREE) 127301107K2	JCTWA07TG004
CN2801	STRAIGHT CONNECTOR BASE 00 8283 0212 00 000	J383C02UG002
RESISTORS		
R2401	CARBON RES. 1/4W G 1.5k Ω	RCX4GATZ0152
R2402	CARBON RES. 1/4W G 1.5k Ω	RCX4GATZ0152
R2403	CARBON RES. 1/4W G 2.2k Ω	RCX4GATZ0222
R2404	CARBON RES. 1/4W G 2.7k Ω	RCX4GATZ0272
R2405	CARBON RES. 1/4W G 4.7k Ω	RCX4GATZ0472
R2406	CARBON RES. 1/4W G 6.8k Ω	RCX4GATZ0682
R2407	CARBON RES. 1/4W G 15k Ω	RCX4GATZ0153
SWITCHES		
SW2401	TACT SWITCH SKQSAB	SST0101AL038
SW2402	TACT SWITCH SKQSAB	SST0101AL038
SW2403	TACT SWITCH SKQSAB	SST0101AL038
SW2404	TACT SWITCH SKQSAB	SST0101AL038
SW2405	TACT SWITCH SKQSAB	SST0101AL038
SW2406	TACT SWITCH SKQSAB	SST0101AL038
SW2407	TACT SWITCH SKQSAB	SST0101AL038
SW2408	TACT SWITCH SKQSAB	SST0101AL038

JUNCTION CBA

Ref. No.	Description	Part No.
	JUNCTION CBA Consists of the following:	-----
CONNECTOR		
CN2504	242 SERIES CONNECTOR TUC-P05X-B1 WHT ST	JCTUB05TG002

